

## Insulated Wall Performance – Thermal & Hygrothermal Dynamics of Cold-Side Vapor Barriers with Rigid Insulation in Mixed and Cold Climates – 2” Exterior Polyisocyanurate Insulation

### ***Abstract:***

Metal stud cavities clad with through-fastened rigid insulation with exterior joint tape alone create a vapor barrier on the cold side of the wall. Temperatures within the non-sealed, interstitial space between insulation panels can create locations that provide temperature changes conducive to generation of condensate and mold.

### ***Description of Wall Assembly Model:***

2” foil-faced polyisocyanurate insulation panels are attached to 6” steel stud framing with #14 galvanized fasteners. The insulation panels have weatherproof joint tape on the exterior and a minimum installed gap of 1/32” (ASTM D2126) between them, with the interior side of the stud attached with gypsum board.

This wall assembly analysis was run on both SOLIDWORKS thermal 3D FEA simulation and WUFI hygrothermal software.

### ***Considerations:***

Incompatible tolerance stacking – per ASTM D2126, the board may have up to 2% variance in dimension in the 48” base width and 96” base length.

Levelness of studs – ASTM C840 requires a tolerance of +/- 1/8” every 10’. The stack effect of these tolerances can create joint gaps that exceed 3/16”, yet are within specified ASTM industry standards. These open gaps create, by default, a cold-side vapor barrier in cold and mixed climates.

### ***Result Summary***

Thermal FEA analysis indicates significant temperature differences providing nucleation sites for condensate.

WUFI simulations utilizing three years of historical weather show six months or more of moisture failure in the interstitial insulation space.

### Isometric - Wall Assembly

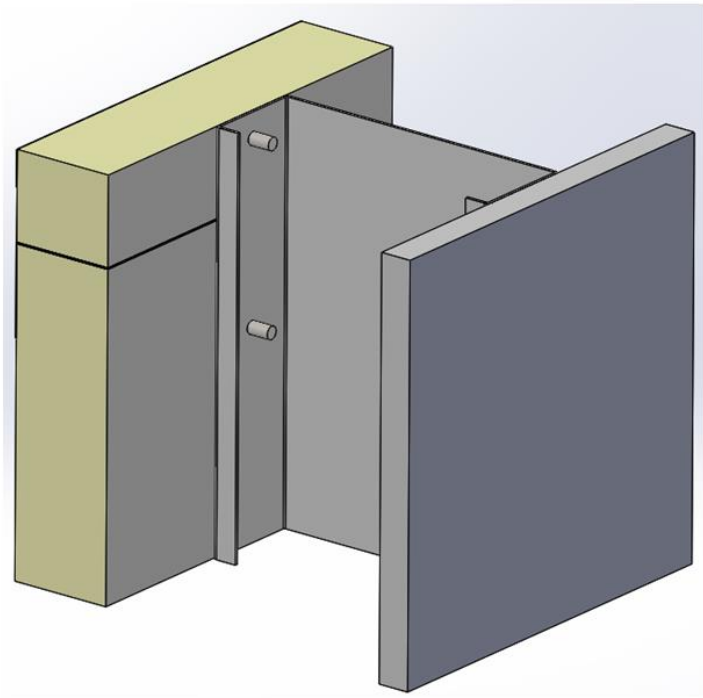
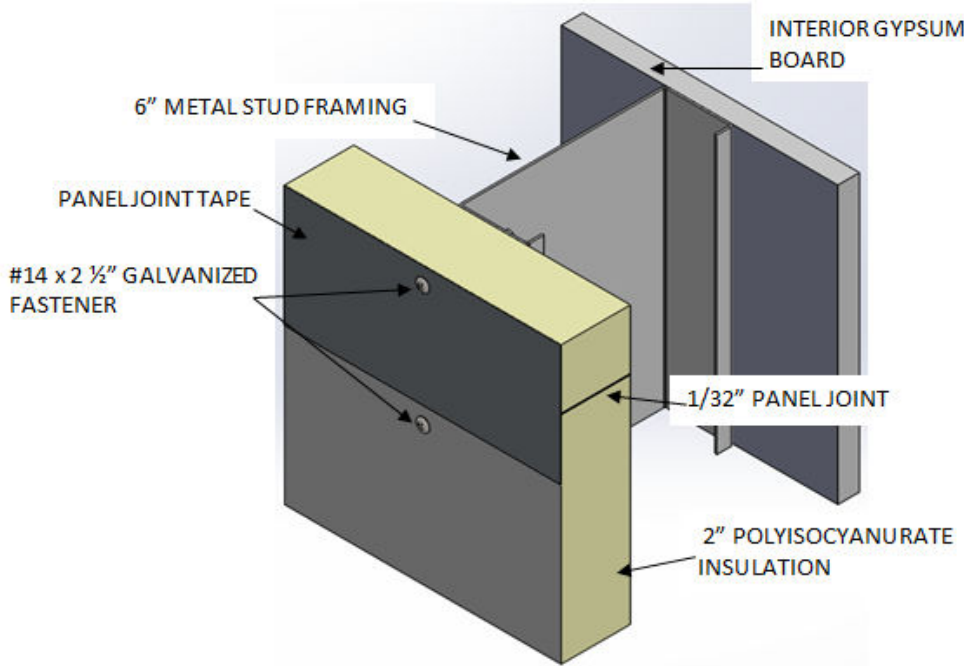

Exterior continuous insulation, with 2" polyisocyanurate, 1/32" gap between insulation panels  
Exterior temperature 0°F / Interior temperature 70°F  
Contact resistances & air film coefficients were incorporated in the model

3D Thermal – Wall Assembly with Temperature Legend

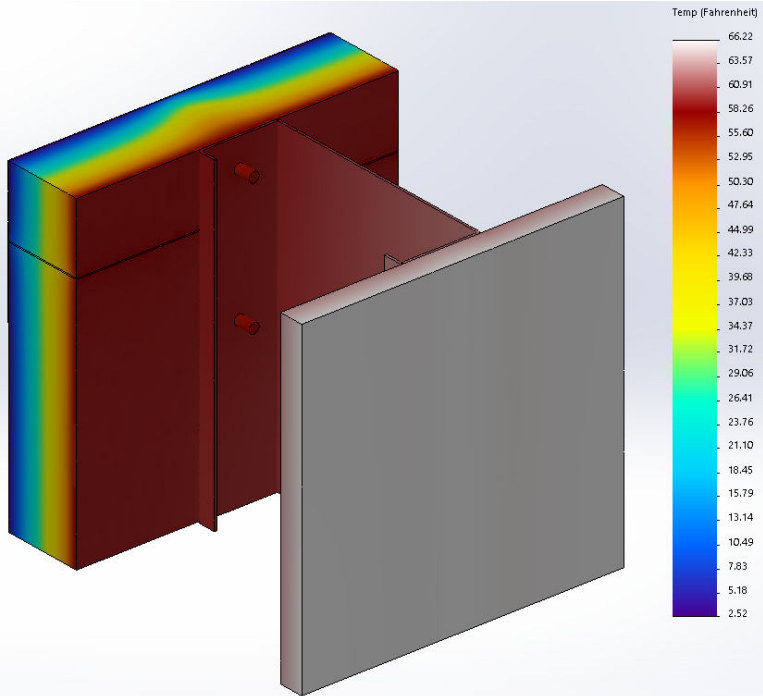
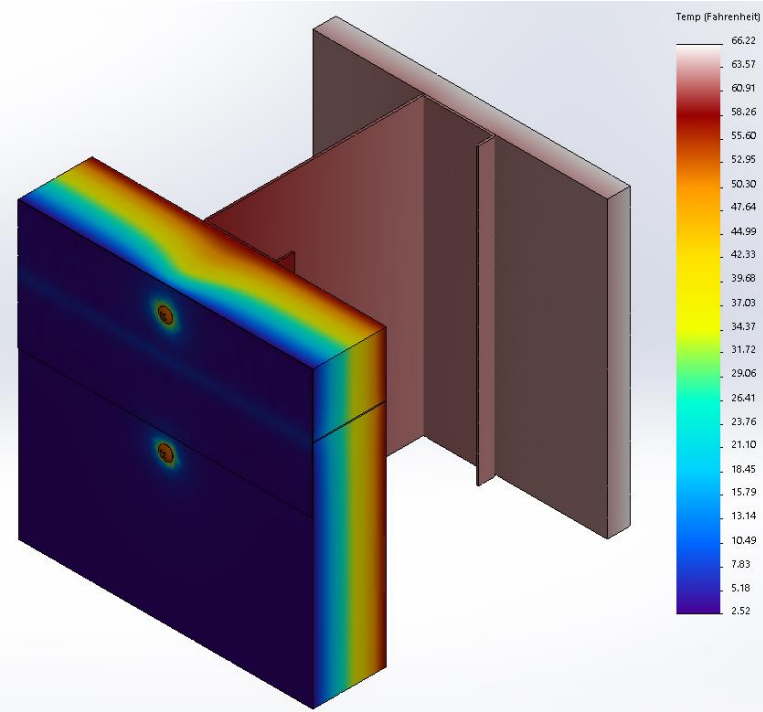

Exterior continuous insulation, with 2" polyisocyanurate, 1/32" gap between insulation panels  
Exterior temperature 0°F / Interior temperature 70°F  
Contact resistances & air film coefficients were incorporated in the model

3D Thermal Section View – Zoomed in at Insulation Joint

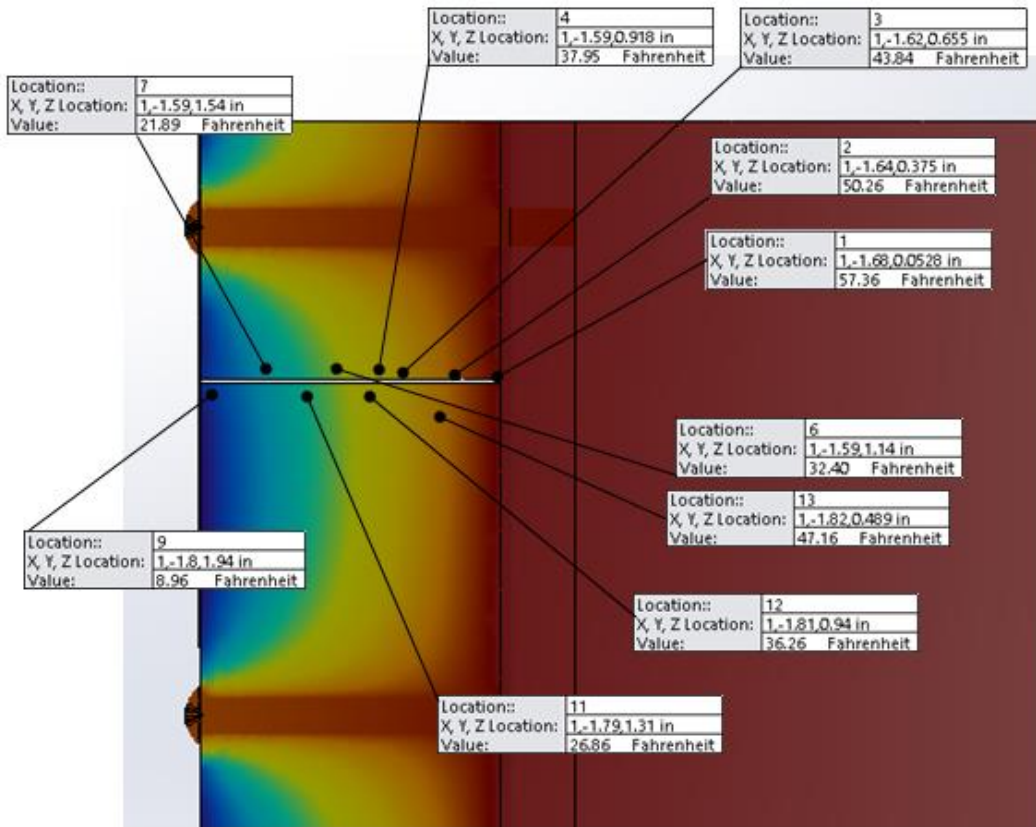
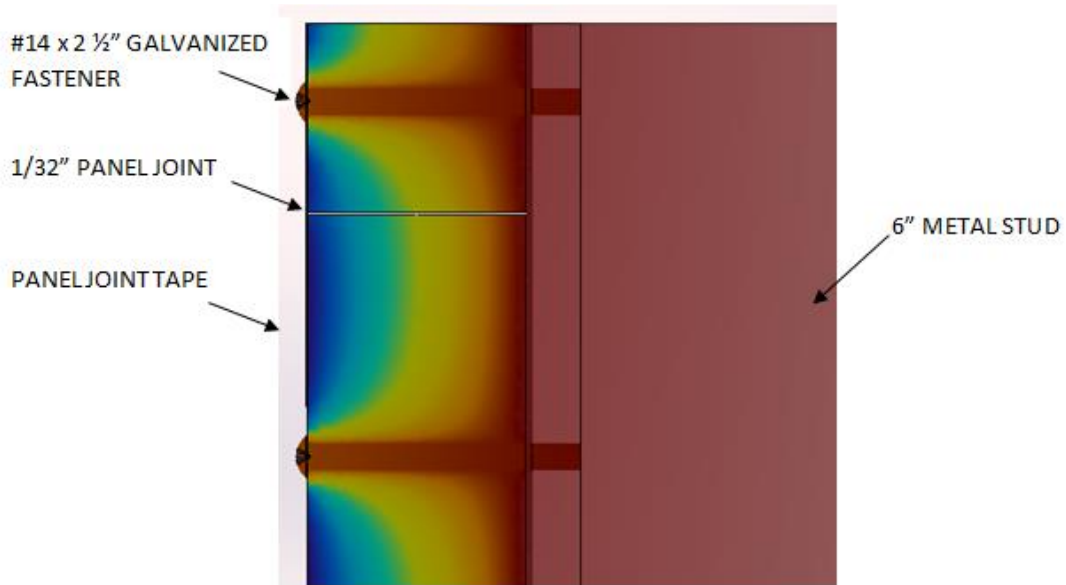

Exterior continuous insulation, with 2" polyisocyanurate, 1/32" gap between insulation panels  
 Exterior temperature 0°F / Interior temperature 70°F  
 Contact resistances & air film coefficients were incorporated in the model

WUFI Zone 5: Chicago

WUFI File Name:	Chicago 2016
Location:	Chicago, Illinois
Climate File:	Warm year
Foam Thickness:	2"
Wall Configuration:	Exterior Tape, Foil Faced Insulation, Air Cavity, Drywall

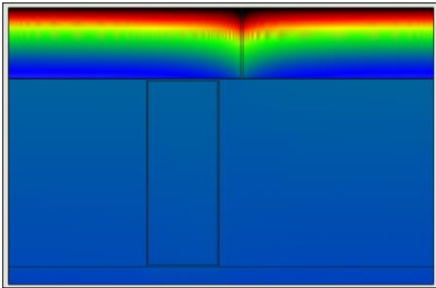
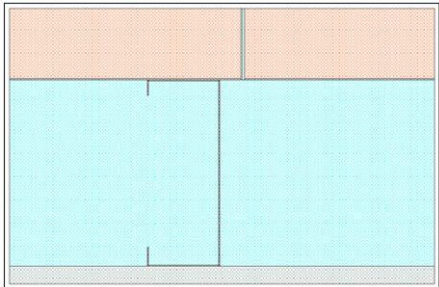

WINTER

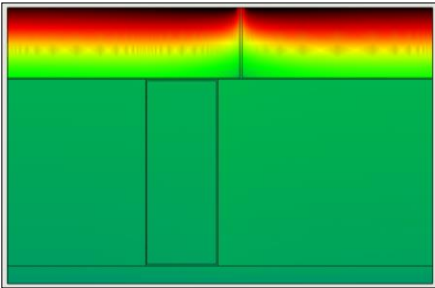

SPRING

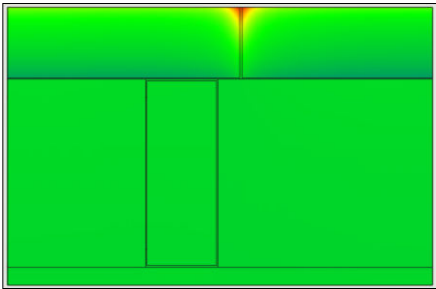

SUMMER

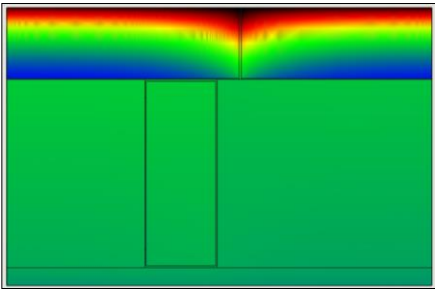

FALL

**Location 1 – Chicago**

**Description:** Foam edge inside structure

**Results:** The location analyzed failed the ASHRAE 160 requirements for 30-Day Running Average for more than half the year.

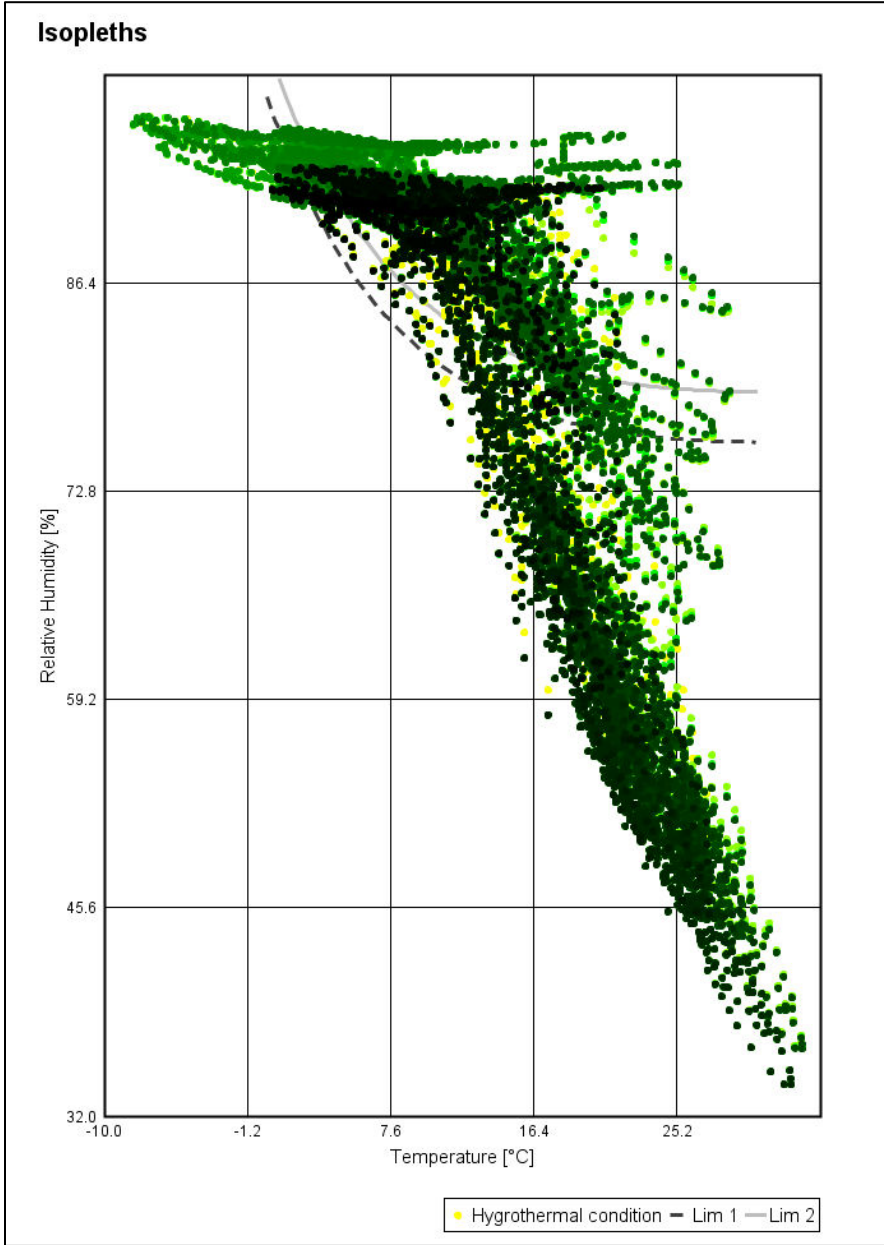

WUFI Zone 5: Chicago

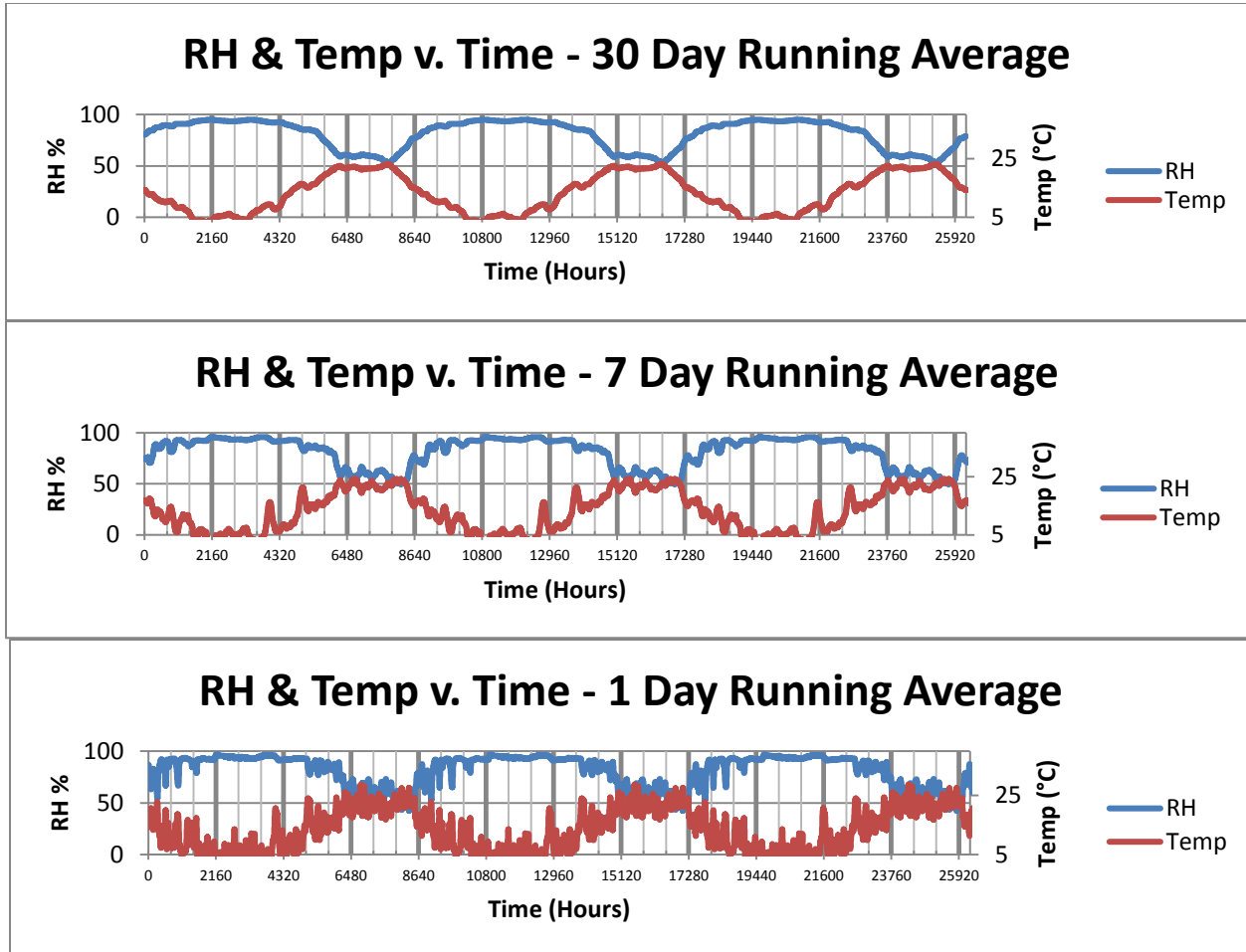

**Conclusion:** The Chicago 2" foam wall assembly with fastener and exterior-applied vapor barrier failed to pass the ASHRAE 160 30-day running average relative humidity criteria. The location of failure was at the seam between the insulation. The assembly trapped moisture in the insulation layer such that it failed the 30-day running average relative humidity at mold-growing concentrations for more than six months out of the year.

**WUFI Zone 4: Baltimore**

WUFI File Name:	MD 2016
Location:	Baltimore, Maryland
Climate File:	Cold Year
Foam Thickness:	2"
Wall Configuration:	Exterior Tape, Foil Faced Insulation, Air Cavity, Drywall

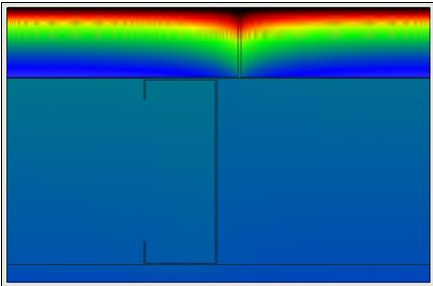
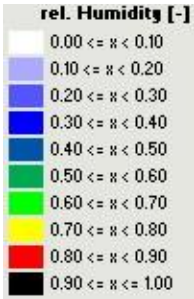
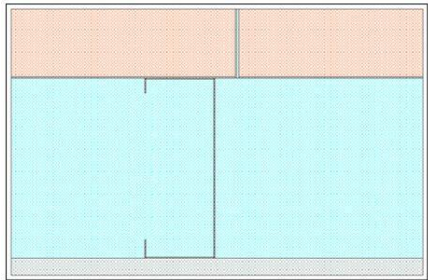

**WINTER**

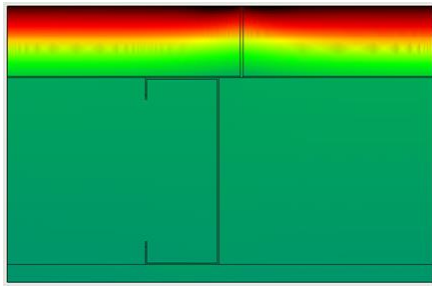

**SPRING**

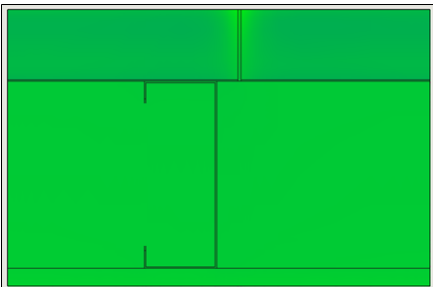

**SUMMER**

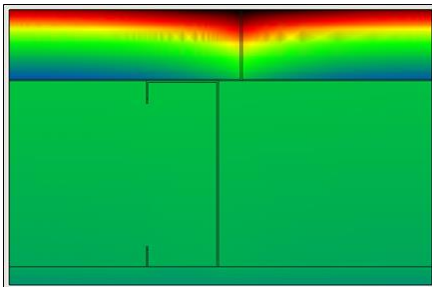

**FALL**



**Location 2 – Baltimore**

**Description:** Foam edge inside structure

**Results:** The location analyzed failed the ASHRAE 160 requirements for 30-Day Running Average for more than half the year.

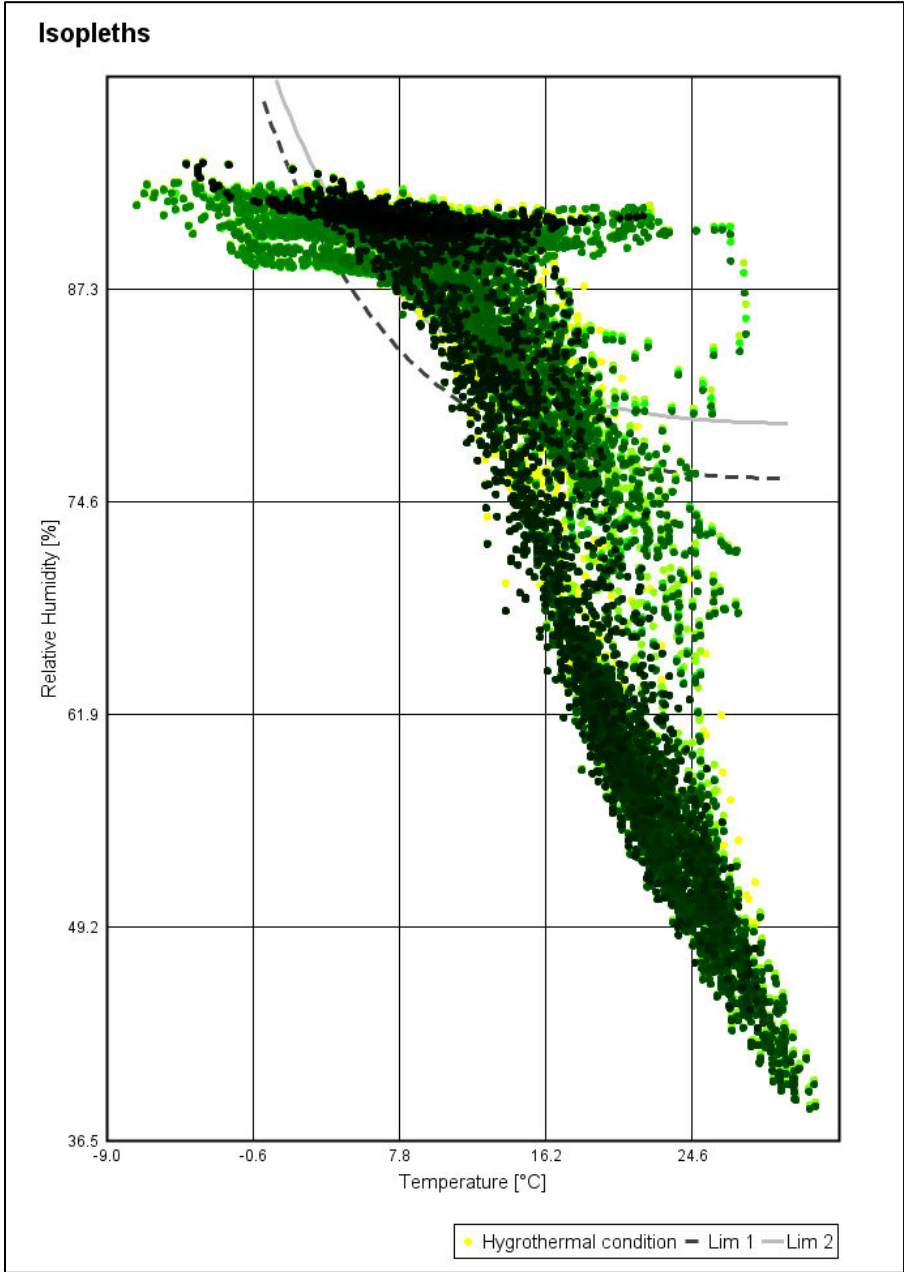

WUFI Zone 4: Baltimore

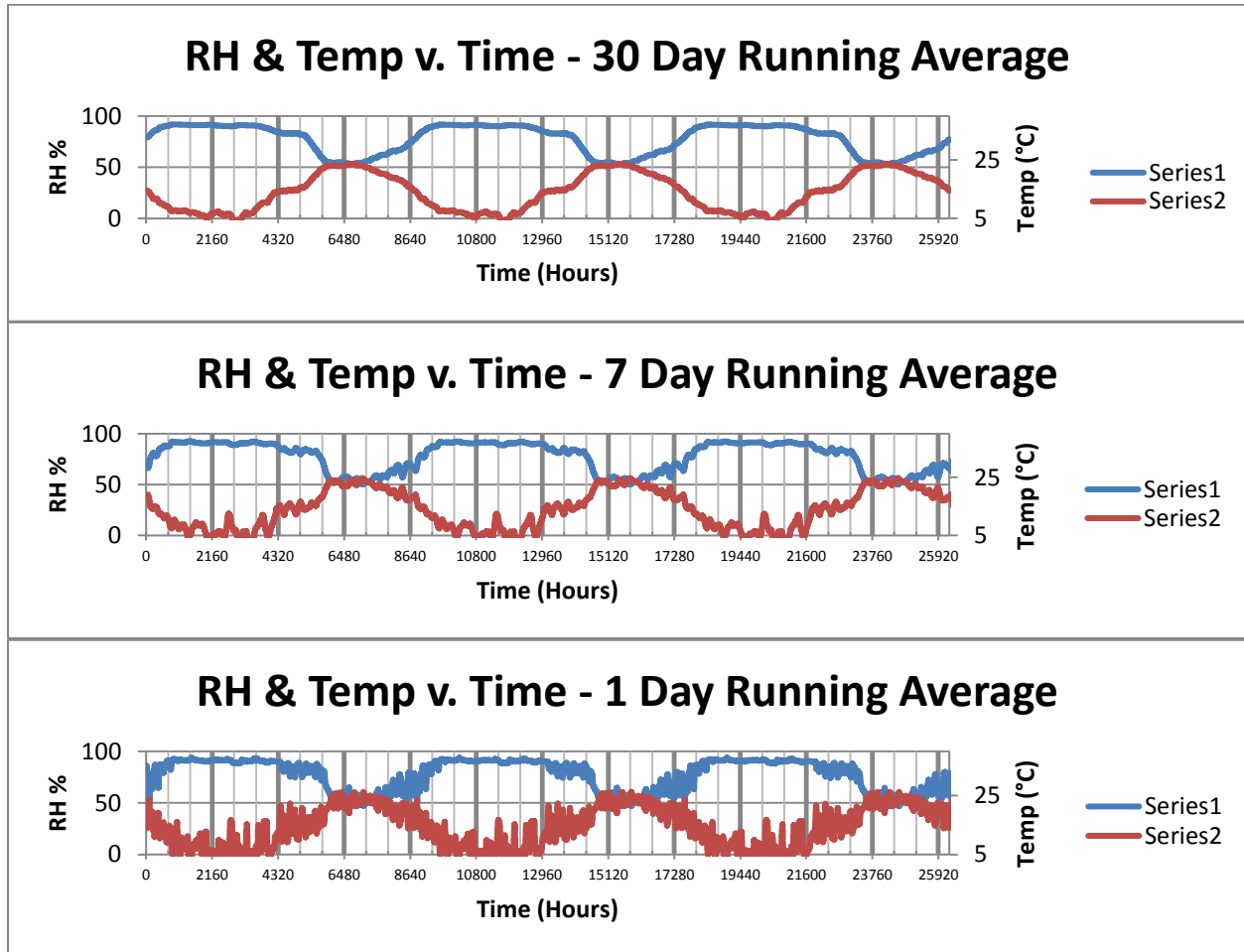

**Conclusion:** The Baltimore 2" foam wall assembly with fastener and exterior-applied vapor barrier failed to pass the ASHRAE 160 30-day running average relative humidity criteria. The location of failure was at the seam between the insulation. The assembly trapped moisture in the insulation layer such that it failed the 30-day running average relative humidity at mold-growing concentrations for more than six months out of the year.

**Disclaimer:** This study should be used for informational purposes only, as it used a custom WUFI setup that conforms to a specific project location and configuration by an independent third party.

**Sources:**

- Hygrothermal simulations done via Wärme Und Feuchte Instationär (WUFI2D).
  - Thermal 3D finite element analysis done via SOLIDWORKS 2015.
  - Historical temperature data acquired through WUFI2D.
- ZK