

GreenGirt DeltaTM

COMPOSITE METAL HYBRID ADJUSTABLE SYSTEM

by **Advanced Architectural Products**

GreenGirt.com

959 Industrial Drive, Allegan, MI 49010

(269) 355-1818

© Copyright 2024. All rights reserved.

GreenGirt Delta Adjustable System

Installation Guide

for Vertical Applications with Z- or L-Base Bracket and Metal L-Rail

GreenGirt Delta Adjustable System



Revolution Labs
Lexington, MA
SGA



Installation Training Video & Course

We invite you to watch the GreenGirt Delta Installation Training Video and to take the eLearning Course, available now on our website, [GreenGirt.com](https://greengirt.com). This comprehensive course is designed to equip you with the knowledge and expertise required to successfully install the GreenGirt Delta system.

To get started, simply scan the QR code below to begin!

**Scan
Here!**



<https://greengirt.com/smartci-3/resources/elearning-training-courses/greengirt-delta-adjustable-system-elearning-training-course/>

Table of Contents

Required Tools & Accessories	2	13E. Jamb Detail	21
Why GreenGirt Delta?	3	13F. Sill Detail	22
Introduction	4	13G. Delta Slider with Steel L-Rail	23
1. System Components	6	13H. Delta Slider with Aluminum L-Rail	24
1A. Base Brackets	6	13I. Delta Slider (Bottom of Rail)	25
– Fixed Base Bracket	7	13J. Delta Slider (Floor Joint)	26
– Expansion Base Bracket	7	14. Construction Details on Metal Studs (Vertical)	27
1B. Vertical Metal L-Rail	8	14A. Wall Section	27
1C. Approved Fasteners	8	14B. Inside Corner Detail	28
2. Description and Uses	9	14C. Outside Corner Detail	29
3. Technical Information	9	14D. Header Detail	30
4. Inspection Upon Delivery	9	14E. Jamb Detail	31
5. System Handling	9	14F. Sill Detail	32
6. System Storage on Site	10	14G. Delta Slider with Steel L-Rail	33
7. Handling and Storage of Auxiliary Accessories	10	14H. Delta Slider with Aluminum L-Rail	34
8. Structural Alignment	11	14I. Delta Slider (Bottom of Rail)	35
9. System Installation: GreenGirt CMH	11	14J. Delta Slider (Floor Joint)	36
10. Installation & Surface Preparation	11	15. Key Installation Reminders	37
11. Installation Requirements	15		
12. Sample Elevation Layout	16		
13. Construction Details on Masonry (Vertical)	17		
13A. Wall Section	17		
13B. Inside Corner Detail	18		
13C. Outside Corner Detail	19		
13D. Header Detail	20		

Disclaimer

IMPORTANT

Please read all information related to the project before receiving materials at the jobsite and before starting the installation.

This installation guide is only to be used with GreenGirt Delta installation drawings, and Advanced Architectural Products (A2P) suggested details. Details shown in project shop drawings take priority over similar information in this manual. Shop drawings may be created either by A2P or by the system installation contractor. A2P's Technical Service Department is available to aid the system installation contractor in the review of shop drawings. This guide is meant to furnish the system installation contractor with recommended methods, procedures, and guidelines for installing the GreenGirt Delta system for commercial/ industrial applications. The information presented is accurate but may not cover all circumstances, building conditions, and/or details of the specific project. Consult an A2P technical representative, as this guide does not cover every unique construction condition.

It is the sole responsibility of the project engineer and system installation contractor to ensure specified air and weather tightness of a building by good design and workmanship in accordance with approved drawings, using only approved sealants/tapes. It is the sole responsibility of the owner's representative and system installation contractor to uphold quality workmanship in accordance with approved shop drawings to ensure the best operation of the system. A2P recommends installers read this document entirely before receiving materials at the job site. The guide is subject to change without notice. Installation information is available through A2P at (269) 355-1818. Follow the architect's approved shop drawings and engineering computations for project-specific fastening designs. The engineer of record is liable for verifying applicable design loads and system fastening requirements. All safety methods are the duty of the installer, general contractor, or construction manager.

Required Tools & Accessories



Levels



Corded / Cordless Screw Guns



Hand Saws



Compact Corded / Cordless Drills



Approved Fasteners



Clamps



Leather Gloves



Basic Safety Equipment

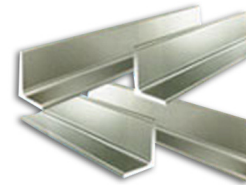

Aluminum Angles & Strapping



Plastic Shims

IMPORTANT

Personnel working with cutting equipment and power tools should wear proper eye protection and safety equipment at all times to prevent injury.

DO NOT USE:



Reciprocating Saw



Impact Drill



Powder Actuated Tools

CAUTION

GreenGirt CMH must NOT be cut with plywood or toothed blades, as it is composed of metal, resin, and glass fibers. Use only abrasive chop saw / hand saw blades. Do not use actuated fasteners, impact hammers / impact drills or reciprocating saws!

Why GreenGirt Delta?

The Problem: Structural Misalignment

Every project has its own unique set of issues that sub-framing systems must be able to adapt to meet today's building challenges. A common problem in construction is structural misalignment and plane deviations within a building's envelope. Using a continuous insulation system that offers plane alignment while simultaneously providing energy-efficient solutions will alleviate unnecessary building challenges and costs.

The Solution: GreenGirt Delta Adjustable System

GreenGirt Delta was designed for the frequent changes in continuous insulation and facade design and meets the demands for energy efficiency and budget constraints. Its individual parts were created as a simple, complete solution to help make smarter buildings. The GreenGirt Delta adjustable system offers a continuous insulation solution for exterior wall and plane deviations. GreenGirt Delta uses structural composite metal hybrid (CMH) components that provide an industry-leading, thermally efficient design while eliminating thermal bridging from metal framing and through-wall fasteners.

GreenGirt Delta provides a solution for structural misalignment ranging from a small fraction of an inch to larger out of plumb issues on vertical installations. The system is available with 18 segmented options and a variety of adjustability from 0.25"–4.5" to meet unique project needs. Easy to specify and designed as a universal cladding attachment system, GreenGirt Delta can be installed on any substrate for retrofit or new construction and for any building height.

Unlike other attachment systems, GreenGirt Delta prevents thermal bridging that is created by metal fasteners and framing. It doesn't create cold spots for condensation inside your walls. GreenGirt Delta also has a universal attachment design for virtually any cladding.

How It Works

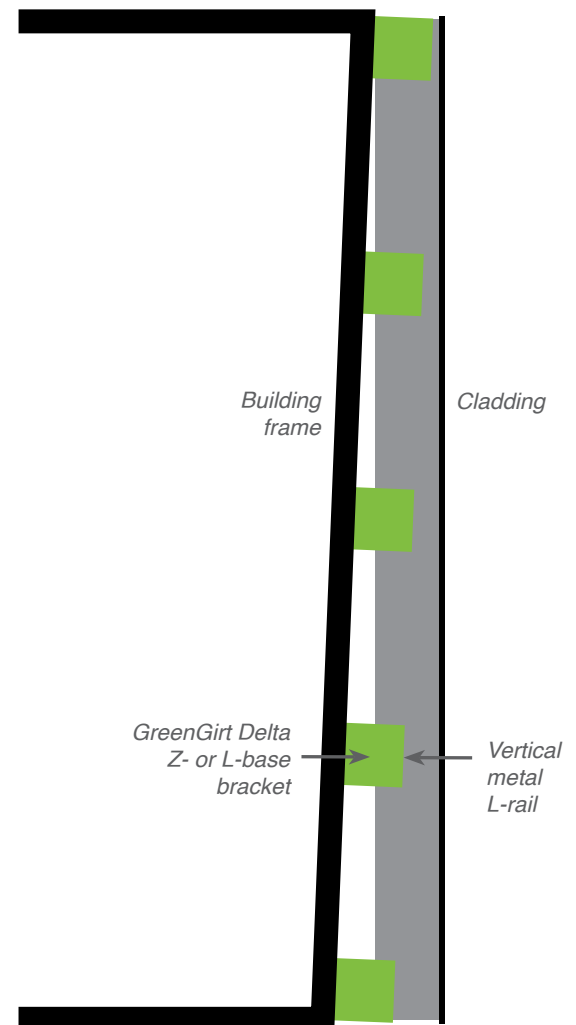

IMPORTANT

Read all information related to the project before receiving materials at the job site and before starting the installation.

Introduction

Welcome to GreenGirt Delta adjustable systems by Advanced Architectural Products. This document serves as the installation guidelines for the GreenGirt Delta adjustable continuous insulation system.

GreenGirt Delta provides buildings with an adjustable continuous insulation solution for exterior wall and plane deviations, and a mounting platform for the cladding application. It is an open design that works with almost any substrate, insulation, or cladding material.

GreenGirt Delta provides a solution for structural misalignment ranging from a small fraction of an inch to more significant out-of-plumb issues on vertical installations. The system is also specifically designed to block off heat gaps that other systems neglect. The thermal efficiency of GreenGirt Delta makes a greener, long-term building investment for the future.

The GreenGirt Delta adjustable system consists of innovative insulated GreenGirt composite metal hybrid (CMH) base brackets, L-rail or clips, and auxiliary accessories as needed.

1. GreenGirt Delta base brackets are available in 2", 3", 4", 5", or 6" depths and should be installed vertically. Standard GreenGirt Delta systems consist of 6" base bracket pieces and L-rails or clips. GreenGirt Delta spacing is typically 16", 24", or 48" on center. Consult an A2P Technical Representative for loading design and capabilities for dead and live loads.
2. Insulation for the GreenGirt Delta adjustable system can be specified as mineral wool.

Installation Requirements for the GreenGirt Delta System:

1. Delta base bracket MUST be installed ONLY according to the shop drawings and GreenGirt Delta specifications.
2. The side-stitch fasteners should ALWAYS go through the FRP into the metal L-rail.
3. Do not cross floor/movement joints with L-rails. This will fail to account for thermal expansion of the substrate and can cause issues down the road.
4. The expansion allowance between floors should be the larger of a ½" gap or what is called out in drawings/specifications between L-rails.
5. Use expansion and fixed brackets according to the details and sample layout.
 - *Aluminum L-Rail:* A 10' section of aluminum L-rail should have two fixed brackets in the middle, with the rest expansion brackets above and below based on spacing requirements. Aluminum L-rails less than 4' long do not need any expansion brackets.
 - *Galvanized Steel L-Rail:* A 10' section of steel L-rail should have three fixed brackets in the middle, with the rest expansion above and below. Galvanized steel L-rails less than 6' long do not need any expansion brackets.
 - *CMH L-Rail:* A 10' section of CMH L-rail should have three fixed brackets in the middle, with the rest expansion above and below. CMH L-rails less than 6' long do not need any expansion brackets.

If there are any setups or situations in which the use of expansion vs. fixed brackets is a question, consult the sample layout and/or contact A2P Engineering.

6. The two required side stitch fasteners MUST be centered in the slots to account for thermal expansion. Putting them at the top or the bottom of the slot defeats its purpose.
7. Every GreenGirt Delta base bracket MUST be attached to the L-rail/clip. Note: Do not leave an L-rail non-mechanically attached.
8. Cladding accommodations for thermal expansion are up to the specific cladding manufacturers and are not the responsibility of A2P.
9. Screws utilized for installation MUST be hex heads.
10. The edge distance of any fastener-hole shall be a minimum of ½" from the edge of the profile to the closest side of the fastener-hole.
11. Impact fasteners/tools should NOT be used with the GreenGirt Delta system.
12. All GreenGirt Delta base brackets must be installed vertically with three fasteners.
13. After self-shimming on the level line, adjust L-rail to be level with the required plane.

1. System Components

GreenGirt Delta CMH Base Bracket with Dual Grip Technology

GreenGirt Delta adjustable system consists of innovative GreenGirt Delta base brackets, a primary insulator, and auxiliary accessories, as needed. The GreenGirt Delta system is available with 18 segmented options with a wide range of adjustability from 0.25"–4.5" variation to meet the unique needs of each project requiring a vertical application.

1A. GreenGirt Delta Base Bracket

Z-Base Bracket vs. L-Base Bracket

GreenGirt Delta base brackets are available in two shapes: Z-profile and L-profile. The Z-profile includes a front flange helping with insulation retention. The L-profile base bracket does not include the front flange, which offers versatility and compatibility with insulation depths. In addition, both the Z- and L-profiles offer the same adjustability range.

Z-Base Bracket

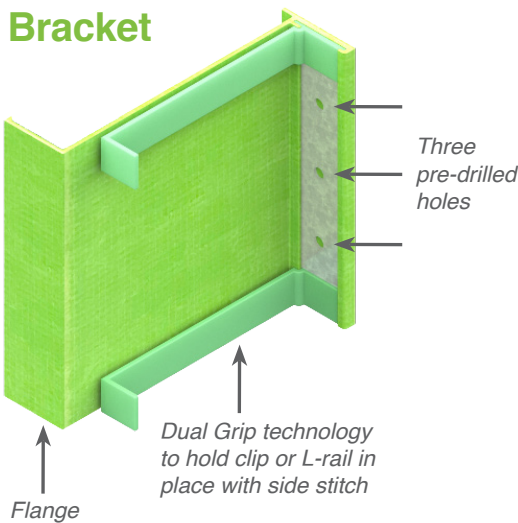

L-Base Bracket

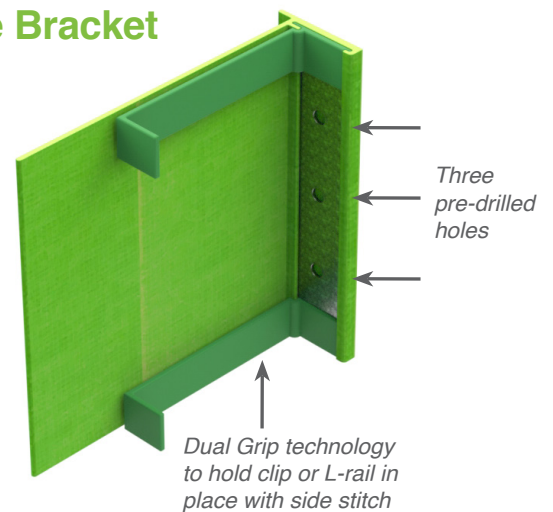

GreenGirt Delta Adjustable System
Z-Base Bracket (with Flange)

Product #	Depth (in)	Range of Adjustment	
		Min.	Max.
3DZ2RGCE	3"	3.25"	7.5"
4DZ3RGCE	4"	4.25"	8.5"
5DZ4RGCE	5"	5.25"	9.5"
6DZ5RGCE	6"	6.25"	10.5"

GreenGirt Delta Adjustable System
L-Base Bracket (no Flange)

Product #	Depth (in)	Range of Adjustment	
		Min.	Max.
3DL2RGCE	3"	3.25"	7.5"
4DL3RGCE	4"	4.25"	8.5"
5DL4RGCE	5"	5.25"	9.5"
6DL5RGCE	6"	6.25"	10.5"

Fixed vs. Expansion GreenGirt Delta Base Brackets

With the wide variances in temperature within a building envelope, thermal expansion must be accounted for. For example, a 10' aluminum rail will expand by almost 3/16" with a 100-degree F change in temperature, and with that expansion comes stress on whatever the L-rail is attached to.

When a vertical continuous L-rail is used, two types of GreenGirt Delta base brackets will be used: fixed and expansion. The expansion base brackets will come pre-punched with two slots, while the fixed brackets will not be punched.

Putting expansion Delta base brackets at the top and bottom of the L-rail helps to accommodate thermal movement. The L-rails also will have a gap in between adjacent rails in order to leave room for thermal expansion. Two fasteners will still be used for every fixed and expansion base bracket and must be fastened into the L-rail.

The number of expansion brackets will vary based on spacing and material.

- *Aluminum L-Rail:* A 10' section of aluminum L-rail should have two fixed brackets in the middle, with the rest expansion brackets above and below based on spacing requirements. Aluminum L-rails less than 4' long do not need any expansion brackets.
- *Galvanized Steel L-Rail:* A 10' section of steel L-rail should have three fixed brackets in the middle, with the rest expansion brackets above and below. Galvanized steel L-rails less than 6' long do not need any expansion brackets.
- *CMH L-Rail:* A 10' section of CMH L-rail should have three fixed brackets in the middle, with the rest expansion brackets above and below. CMH L-rails less than 6' long do not need any expansion brackets.

Expansion Base Bracket



Fixed Base Bracket

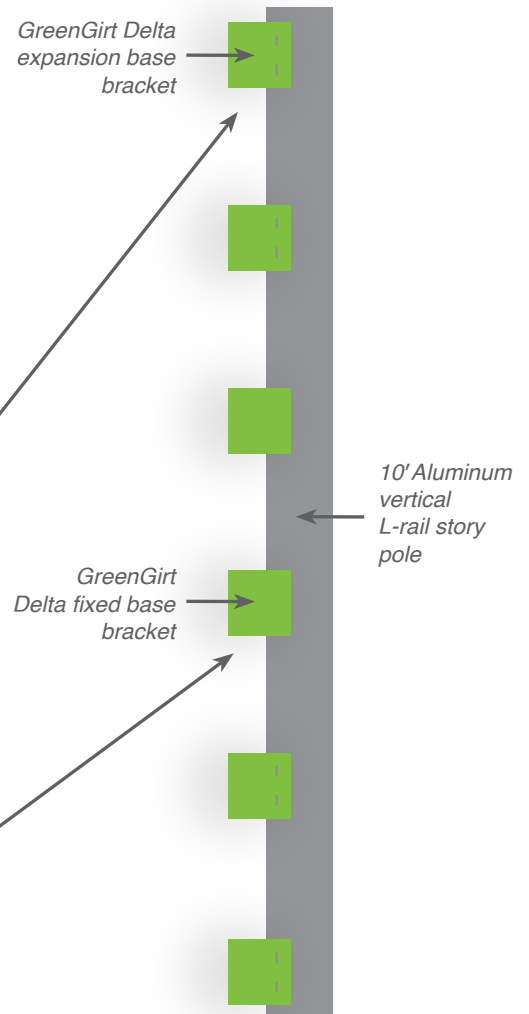
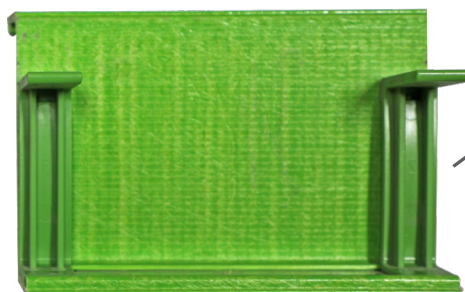

***Reference engineered shop drawings for fixed vs. expansion bracket locations and placement.**

1B. Vertical Metal L-Rail



Vertical Metal L-Rail						
Material	Product #	Length	Dim.	Dim.	Dim.	Dim.
Galvanized Steel	MGAL VR10	10'	1.5" x 3"	1.5" x 4"	1.5" x 5"	1.5" x 6"
Aluminum	MALU VR10	10'	1.5" x 3"	1.5" x 4"	1.5" x 5"	1.5" x 6"

1C. Approved Fasteners

Fasteners for Z-Base Bracket
Attachment to Studs



Washed Head
1/4"-14 Fastener (T3)

Fasteners for Z-Base Bracket
Attachment to Masonry Walls



1/4" Threaded and Coated
Masonry Fastener

Fasteners for side stitching from Z-Base Bracket to Steel/Aluminum/CMH L-Rail



Washed Head
1/4"-14 Fasteners (T3)



Washed Head
1/4"-14 Fasteners (T5)

IMPORTANT

Ensure correct fasteners are used. Side stitch fasteners
MUST go from CMH into metal.

2. Description and Uses

The GreenGirt Delta system is an innovative, complete adjustable continuous insulation solution. Engineered as an adjustable continuous insulation system, the GreenGirt Delta system includes *GreenGirt composite metal hybrid (CMH)* base brackets, L-rail or clips, an engineered installation package, and optional accessories.

GreenGirt Delta joins the building cladding and insulation to a structure. It's an insulated composite metal hybrid (CMH) sub-framing component that can be installed vertically.

3. Technical Information

2.1 Performance & Quality

Please note failure to follow the precise procedures outlined in this Installation Guide, all applicable laws, ordinances, and codes, and/or accepted industry safety procedures will render any and all warranties null and void. A2P will not be responsible in any way for merchandise, installed or not, that is damaged or defective as a result of negligible practices and/or a failure to follow these guidelines, deficiencies in workmanship or construction, or dangerous site conditions.

Warranties and other product information are available from A2P. For information regarding general and product-specific warranties, please contact A2P at (269) 355-1818.

4. Inspection Upon Delivery

GreenGirt Delta is professionally packaged, wrapped, and carefully shipped on flatbed trailers to the construction site. When a shipment is received, check all items against the shipping document for quantities, dimensions, colors, transit damage, etc. Document any shortage of girts and accessories or any damage on the bill of lading and have it signed by the driver. It is the receiver's responsibility to make any damage claims immediately. Please note that although every effort is made to prevent shipping damage, A2P is not responsible for damage that may occur during transportation, delivery, storage, or on-site handling.

5. System Handling

5.1 Pallets Handled by Forklift

Inspect travel route to assure a reasonable level and compacted surface free of ruts and excavations.

Prior to moving any pallet, ensure all boxes are secured. The recommended loading/unloading method for boxes is to use a single forklift with appropriately-spaced forks placed under the center of the pallet, transporting only one at a time.

Note: Do not stack pallets on top of boxes.

5.2 Pallets Handled by Crane

Carefully pick up boxes one at a time to prevent damage while lifting.

Prior to lifting any pallet, ensure all boxes are secured. The recommended crane lifting method is to use nylon straps positioned at a minimum of two points along the length of the pallet. Suitable wood spreaders should be used and located at the top and bottom of the pallets at the strap positions to protect the edges.

Extreme care should be taken to avoid bumping pallets when lifting.

6. System Storage on Site

The site must have adequate storage space to receive and store GreenGirt Delta components. This space must be level, firm, clean, and free from standing water. Components should be stored in a dry condition, off the ground, and covered continuously when not in use. Avoid outdoor storing for longer than 45 days.

If GreenGirt Delta components are to be used immediately, pallets/boxes should be placed at preplanned strategic locations around the building perimeter, as close as possible to the specific work areas. Review installation shop drawings to determine the best locations.

When handling GreenGirt Delta components, ropes, steel cables, or chains must not be used.

IMPORTANT

GreenGirt CMH packages are non-load bearing! Do NOT stack other objects on top of the bundles, such as bricks, metal, lumber, and other materials.

7. Handling and Storage of Auxiliary Accessories

Care should be taken during unloading and storage to prevent damage to items, such as GreenGirt Delta base brackets, clips, or L-rails.

Cover all pallet crates or boxes to protect materials from the weather but allow for ventilation to prevent condensation. Temperature-sensitive items such as butyl tapes and sealants should be stored under controlled conditions to maintain suitable application characteristics.

8. Structural Alignment

Review shop drawings before installation to verify that structural members are in the correct location.

Installer must examine the alignment of the substrate before installation of the GreenGirt Delta system. The substrate must be examined for plane deviations or structural misalignment, and support members to which panels are attached must be in the same plane, flat and free of obstructions such as weld marks, bolts or screw heads.

Support members shall be installed within the following tolerances of plus or minus 1/8" (3.17 mm) in 10' (3048 mm) in any direction along the plane of framing, with non-accumulative spaces.

Any variance from tolerances can affect performance and aesthetics and must be reported to the architect and general contractor and corrected by the responsible party before installation begins.

9. System Installation: GreenGirt CMH

When attaching fasteners to GreenGirt CMH, the following general guidelines are to be observed:

1. The edge distance of any fastener-hole shall be a minimum of ½" from the edge of the profile to the closest side of the fastener-hole.
2. The minimum clear distance between holes is 5x diameter.
3. The minimum edge (edge of profile to edge of hole) distance in the longitudinal direction is 3x diameter.
4. The minimum edge (edge of profile to edge of hole) distance in the transversal direction is 2x the diameter.

10. Installation & Surface Preparation

Before installing GreenGirt Delta, ensure that the substrate is dry, clean, sound, and free of any debris, residue, and any other surface contaminants.

Orientation: GreenGirt Delta Z- or L-base brackets can only be installed vertically.

Alignment: GreenGirt Delta Z- or L-base brackets must be aligned vertically to place metal clips and hat channels.

10.1 Installer Selection

A2P recommends that the GreenGirt Delta system is only installed under the direct supervision of an experienced craftsman trained in properly applying its diverse offering of products and services. Please call (269) 355-1818 for information regarding authorized installer selection and training programs.

IMPORTANT

Ensure brackets are aligned vertically to each other on substrate.
A2P should be contacted for all projects to verify allowable spacing.

10.2 Masonry & Concrete

Remove high spots and fill in low spots before attaching GreenGirt Delta to concrete or masonry substrate. Remove any extra materials protruding on the surface of walls, such as chunks of mortar or concrete, and even wall surface to within 1/4" per 8'.

GreenGirt Delta Z- or L-base brackets must be flat against the substrate and perpendicular to the plane of the substrate. Fasten GreenGirt Delta Z- or L-base brackets vertically to the masonry substrate with approved threaded and coated 1/4" masonry fasteners of sufficient loading capacity for the application utilizing **all three pre-drilled holes** in the steel insert. Fastening is predicated by project specifications and requirements.

(Applies to both Z- or L-base bracket)

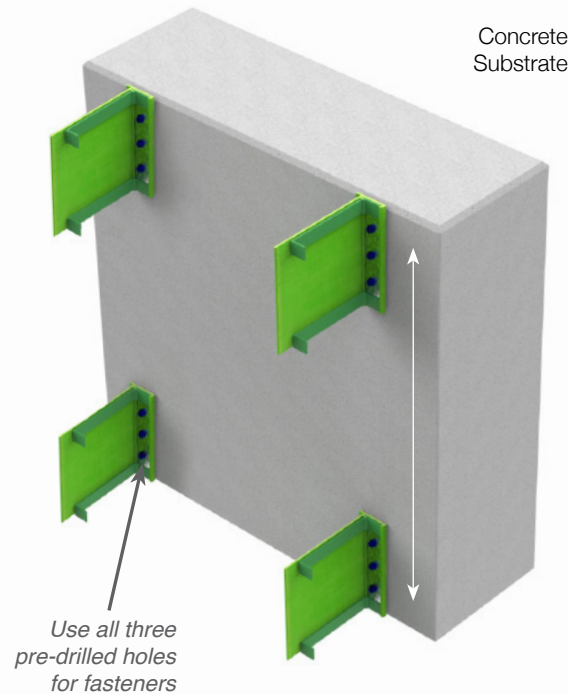

10.3 Steel & Wood Stud

Verify the substrate is flat, without steps or voids greater than 1/4" over a 20' span. GreenGirt Delta Z- or L-base brackets must be flat against the substrate and perpendicular to the plane of the substrate. Attach GreenGirt Delta Z- or L-base brackets vertically to framing with approved 1/4 x 14 fasteners of sufficient loading capacity for the application, using **all three pre-drilled holes** in the steel insert. Fastening is predicated by project specifications and requirements.

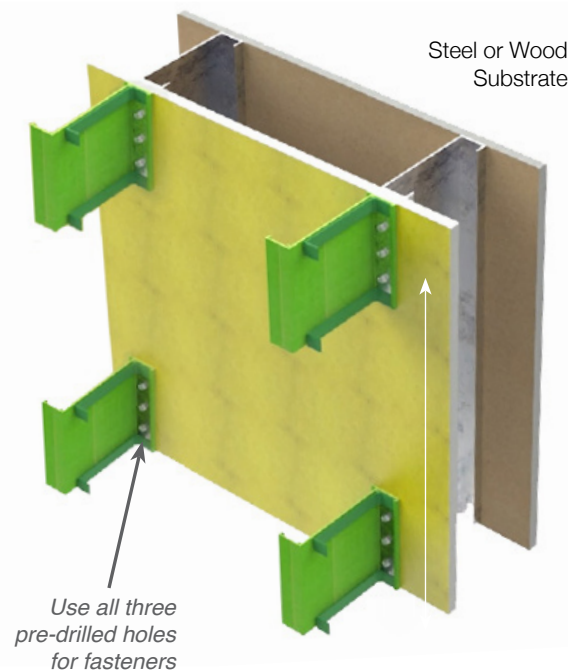

CAUTION

Impact fasteners or impact power tools should not be used to install GreenGirt Delta Z- or L-base brackets with any substrate.

10.4 Metal L-Rail Fastening

The metal L-rail may be made of aluminum or steel. Secondary material or scrap should not be used for either type of rail.

Vertical Clip Install

Fiber-reinforced polymer (FRP) material should never be the final material fastened into when attaching to a metal L-rail from the GreenGirt Delta Z- or L-base bracket. If an aluminum or steel L-rail is used, the attachment should be fastened through the FRP into the aluminum or steel rail. Two staggered fasteners with 5/8" washers should be used to attach the metal L-rail to every GreenGirt Delta Z- or L-base bracket, with the fasteners being spaced apart by at least five times the diameter of the fastener.

The metal L-rail used with the GreenGirt Delta Z- or L-base bracket should be attached so that at least 1½" of the depth of the clip is attached to the Z- or L-base bracket. If a deeper metal L-rail is needed, a deeper Z- or L-base bracket should be used.

Special attention is required at terminations and floor lines.

Z-Base Bracket with Metal L-Rail
(with Flange)

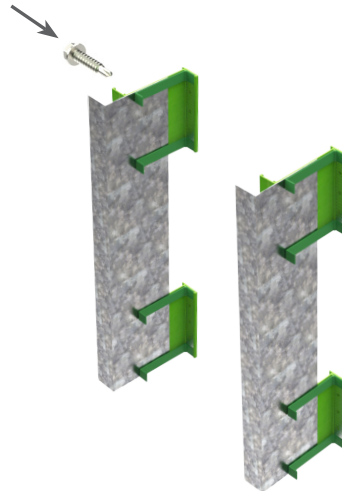

L-Base Bracket with Metal L-Rail
(Without Flange)

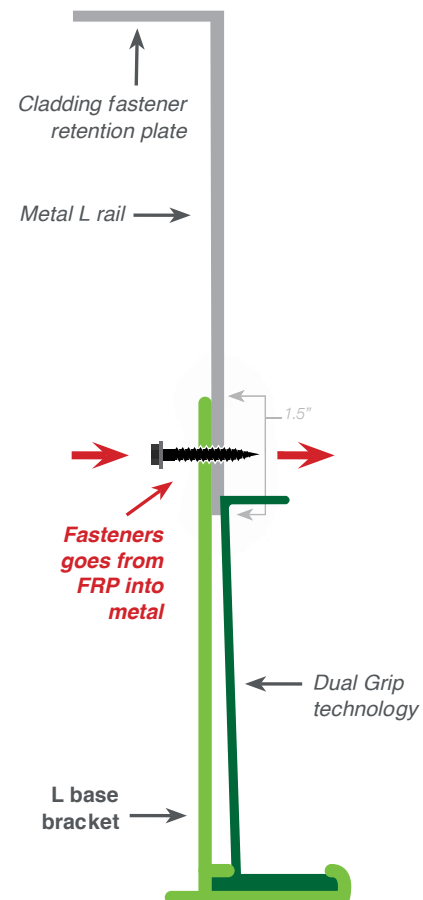
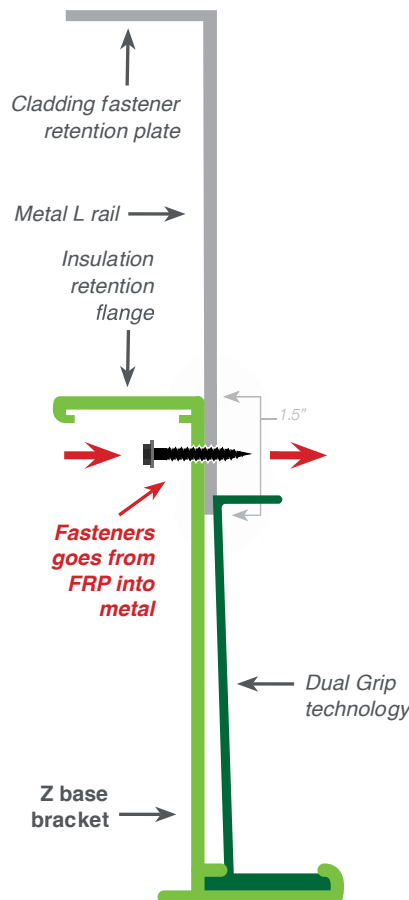
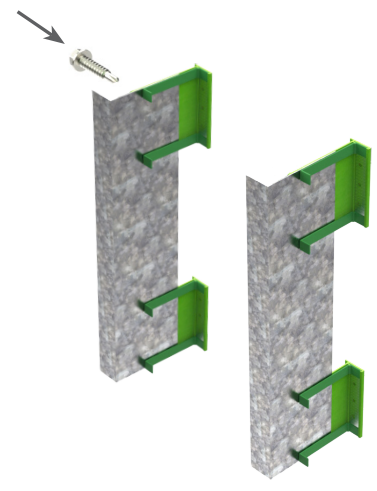

IMPORTANT
Ensure correct fasteners are used.
Side stitch fasteners **MUST** go from FRP into metal.

10.5 Insulation

Mineral wool must be used with the GreenGirt Delta System. Certain cladding types have a maximum air gap when tested for NFPA 285 compliance, and using the adjustable CMH system does not exempt one from that requirement. For best practices, mineral wool should fill from the back of the GreenGirt Delta Z-base brackets to the front of the rail. If the cladding assembly allows, mineral wool can be used with just the GreenGirt Delta Z-base brackets and placed within the rails around openings to avoid a “chimney effect” for fire.

Insert mineral wool insulation left to right, utilizing the Dual Grip retention technology to puncture the insulation on the left side and tuck the insulation behind the GreenGirt base bracket flange on the right side.

Note: All insulation requirements are predicated by the project specifications and requirements.

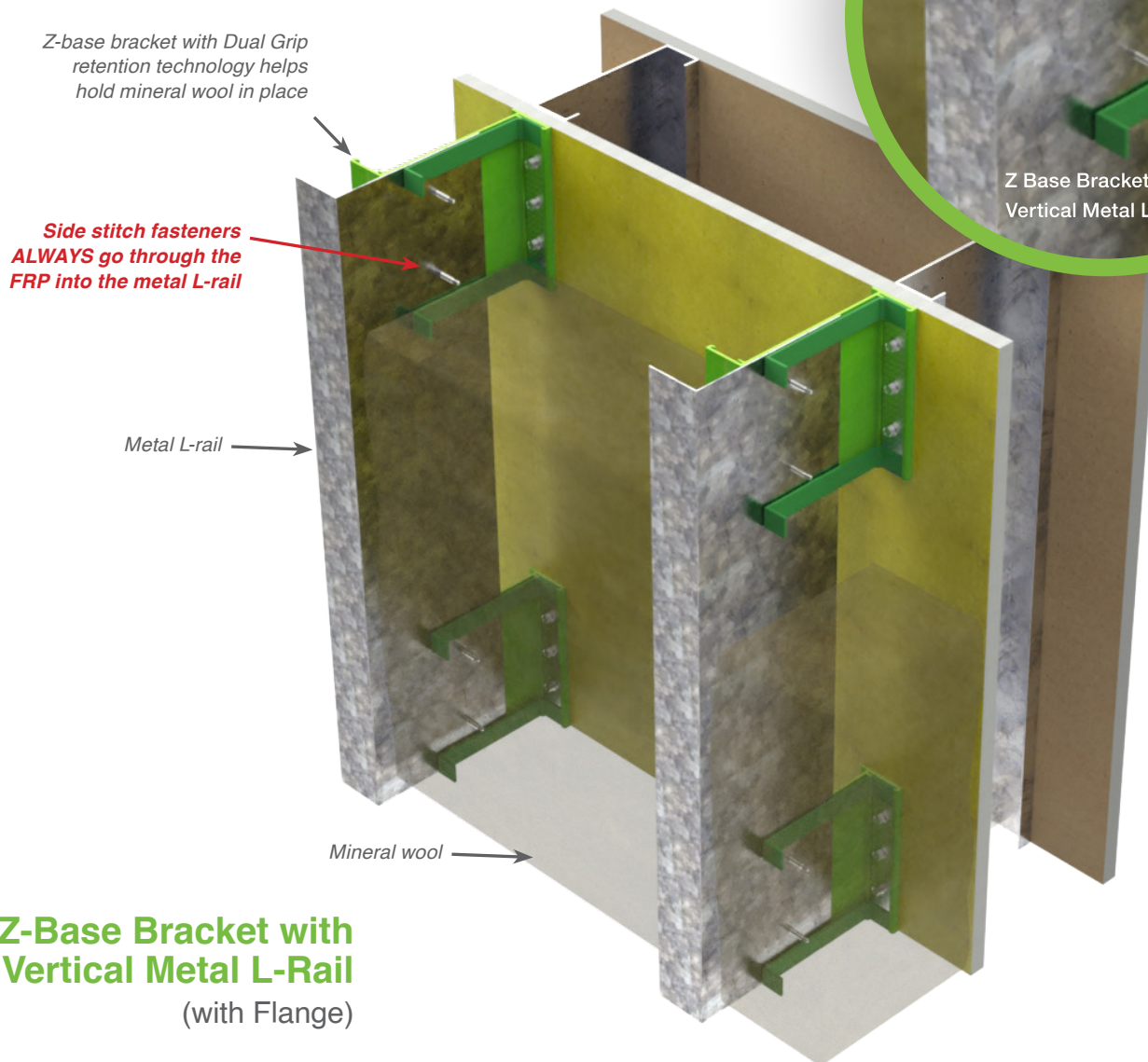
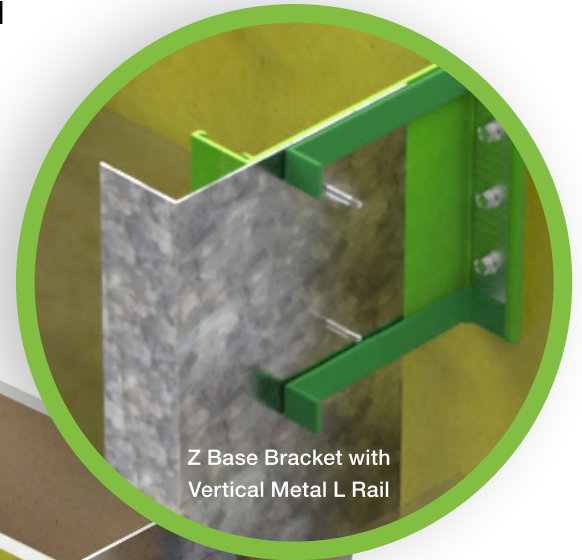

Z-Base Bracket with Vertical Metal L-Rail (with Flange)

A2P is only responsible for the thermal expansion of the sub-framing of the GreenGirt Delta System. The cladding manufacturer is responsible for handling the thermal expansion of the cladding, as well as compatibility with the GreenGirt Delta System.

11. Installation Requirements

The following pages include a sample elevation layout and sample details that state what to do at floor joints, L-rail terminations, etc.

The sample layout shows where the rows of fixed vs. expansion Delta base brackets go on a typical elevation. It also indicates that a bracket is needed at the top and bottom of the L-rails and that the L-rail cannot cross floor/movement joints. Those respective details are found in the pages following the sample layout.

1. Delta base bracket **MUST** be installed **ONLY** according to the shop drawings and GreenGirt Delta specifications.
2. The side-stitch fasteners should **ALWAYS** go through the FRP into the metal L-rail.
3. Do not cross floor/movement joints with L-rails. This will fail to account for thermal expansion of the substrate and can cause issues down the road.
4. The expansion allowance between floors should be the larger of a ½" gap or what is called out in drawings/specifications between L-rails.
5. Use expansion and fixed brackets according to the details and sample layout.
 - *Aluminum L-Rail*: A 10' section of aluminum L-rail should have two fixed brackets in the middle, with the rest expansion brackets above and below based on spacing requirements. Aluminum L-rails less than 4' long do not need any expansion brackets.
 - *Galvanized Steel L-Rail*: A 10' section of steel L-rail should have three fixed brackets in the middle, with the rest expansion brackets above and below. Galvanized steel L-rails less than 6' long do not need any expansion brackets.
 - *CMH L-Rail*: A 10' section of CMH L-rail should have three fixed brackets in the middle, with the rest expansion brackets above and below. CMH L-rails less than 6' long do not need any expansion brackets.



If there are any setups or situations in which the use of expansion vs. fixed brackets is a question, consult the sample layout and/or contact A2P Engineering.

6. The two required side stitch fasteners **MUST** be centered in the slots to account for thermal expansion. Putting them at the top or the bottom of the slot defeats its purpose.
7. Every GreenGirt Delta base bracket **MUST** be attached to the L-rail/clip. Note: Do not leave an L-rail non-mechanically attached.
8. Cladding accommodations for thermal expansion are up to the specific cladding manufacturers and are not the responsibility of A2P.
9. Screws utilized for installation **MUST** be hex heads.
10. The edge distance of any fastener-hole shall be a minimum of ½" from the edge of the profile to the closest side of the fastener-hole.
11. Impact fasteners/tools should **NOT** be used with the GreenGirt Delta system.
12. All GreenGirt Delta base brackets must be installed vertically with three fasteners.
13. After self-shimming on the level line, adjust L-rail to be level with the required plane.

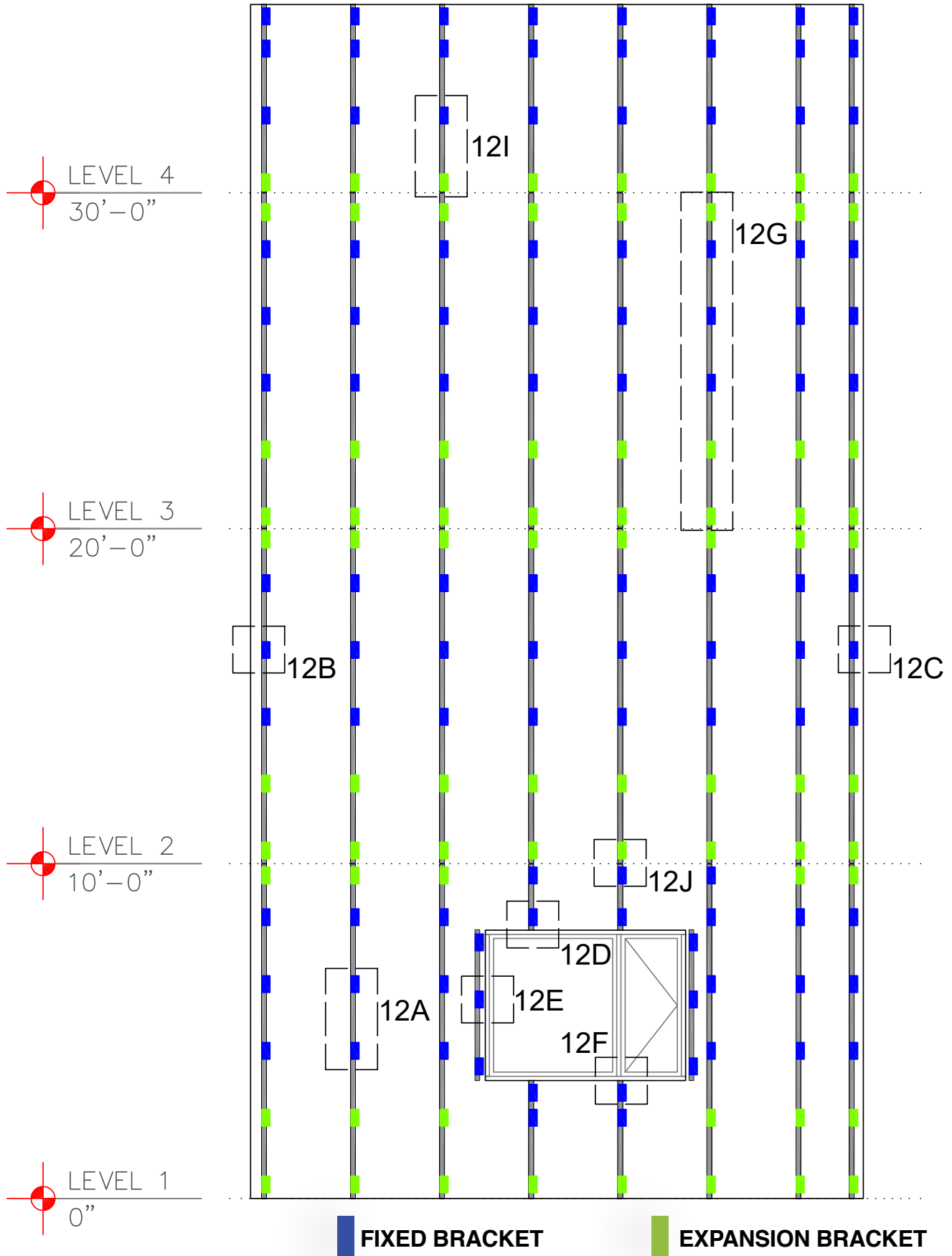
12. Sample Elevation Layout

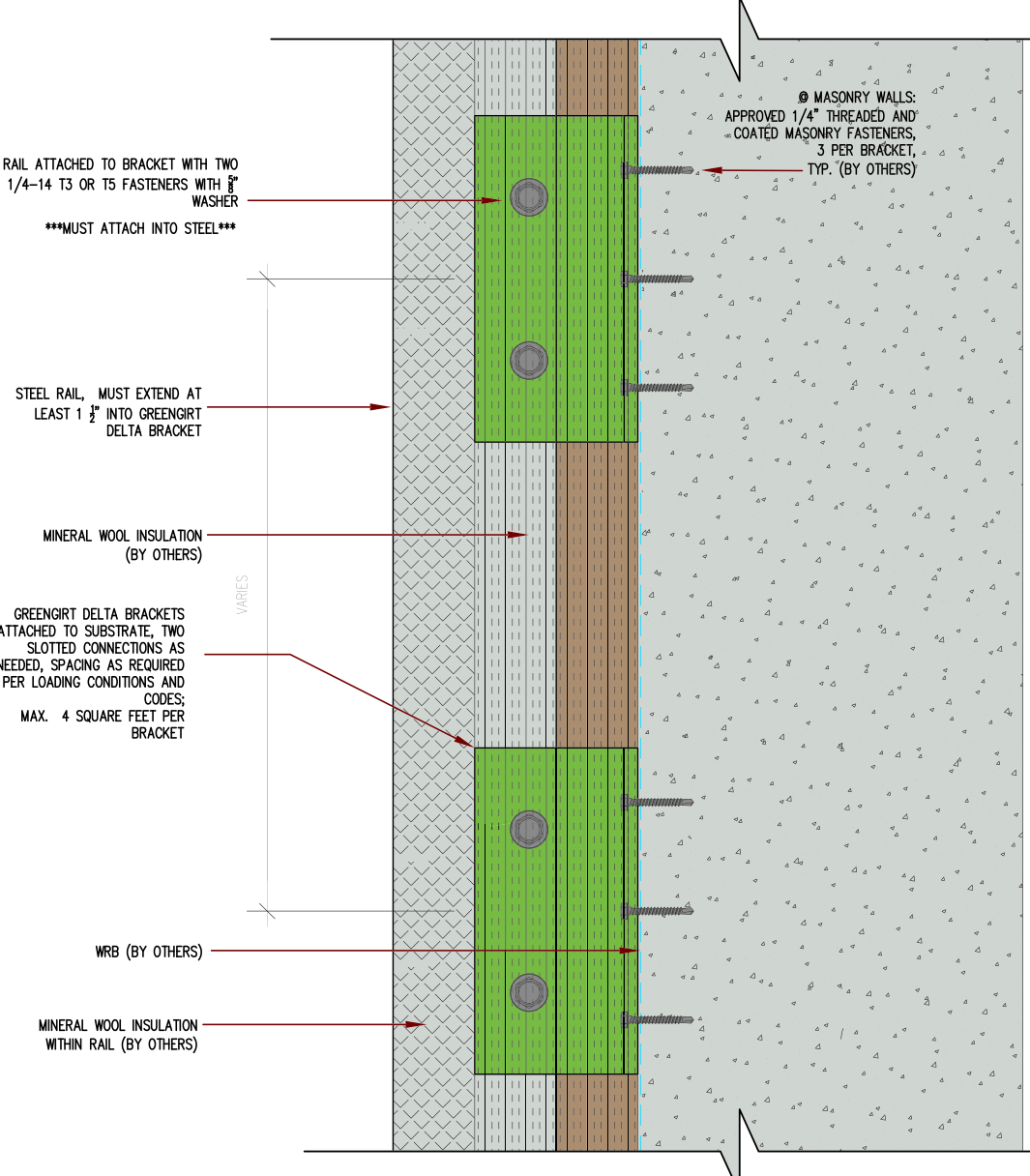

13A. Construction Details on Masonry (Vertical) - Wall Section

 <p>ADVANCED ARCHITECTURAL PRODUCTS</p>	<p>NOTE: DETAILS ARE PROVIDED FOR INFORMATION ONLY, AND ARE SUBJECT TO CHANGE WITHOUT NOTICE. SPECIFIC PROJECT ENGINEERING BY OTHERS WILL ADDRESS ATTACHMENT SPACING, ORIENTATION AND LOADING. CONTACT ADVANCED ARCHITECTURAL PRODUCTS FOR FURTHER DETAILS, AND TO INQUIRE ABOUT UPDATES AND REVISIONS ADVANCED ARCHITECTURAL PRODUCTS IS ONLY RESPONSIBLE FOR THE THERMAL EXPANSION OF THE SUBFRAMING OF THE ADJUSTABLE SYSTEM. THE CLADDING MANUFACTURER IS RESPONSIBLE FOR HANDLING THERMAL EXPANSION OF THE CLADDING AS WELL AS THERMAL EXPANSION COMPATIBILITY WITH THE ADJUSTABLE SUBFRAMING.</p>						
							
<p>RAIL ATTACHED TO BRACKET WITH TWO 1/4-14 T3 OR T5 FASTENERS WITH 5/8\"</p> <p>***MUST ATTACH INTO STEEL***</p> <p>STEEL RAIL, MUST EXTEND AT LEAST 1 1/2\"</p> <p>MINERAL WOOL INSULATION (BY OTHERS)</p> <p>GREENGIRT DELTA BRACKETS ATTACHED TO SUBSTRATE, TWO SLOTTED CONNECTIONS AS NEEDED, SPACING AS REQUIRED PER LOADING CONDITIONS AND CODES; MAX. 4 SQUARE FEET PER BRACKET</p> <p>WRB (BY OTHERS)</p> <p>MINERAL WOOL INSULATION WITHIN RAIL (BY OTHERS)</p>	<p>○ MASONRY WALLS: APPROVED 1/4\"</p>						
 <p>COMPOSITE METAL HYBRID ADJUSTABLE SYSTEM</p> <p>GreenGirt.com (269) 355-1818</p>	<table border="1" style="width: 100%; border-collapse: collapse;"> <tr> <td style="width: 50%;">SUBSTRATE: MASONRY</td> <td style="width: 50%;">INSULATION: MINERAL WOOL</td> </tr> <tr> <td>CLADDING:</td> <td>DATE</td> </tr> <tr> <td>GREENGIRT DELTA BRACKET SIZE: 300 / 3"</td> <td>ORIENTATION: VERTICAL Z-BRACKET</td> </tr> </table> <h2 style="text-align: center; margin: 0;">3" STEEL RAIL WITH 3" DELTA</h2> <p style="text-align: center; font-size: small;">NOT TO SCALE</p>	SUBSTRATE: MASONRY	INSULATION: MINERAL WOOL	CLADDING:	DATE	GREENGIRT DELTA BRACKET SIZE: 300 / 3"	ORIENTATION: VERTICAL Z-BRACKET
SUBSTRATE: MASONRY	INSULATION: MINERAL WOOL						
CLADDING:	DATE						
GREENGIRT DELTA BRACKET SIZE: 300 / 3"	ORIENTATION: VERTICAL Z-BRACKET						

13B. Masonry - Inside Corner Detail



NOTE: DETAILS ARE PROVIDED FOR INFORMATION ONLY, AND ARE SUBJECT TO CHANGE WITHOUT NOTICE. SPECIFIC PROJECT ENGINEERING BY OTHERS WILL ADDRESS ATTACHMENT SPACING, ORIENTATION AND LOADING. CONTACT ADVANCED ARCHITECTURAL PRODUCTS FOR FURTHER DETAILS, AND TO INQUIRE ABOUT UPDATES AND REVISIONS. ADVANCED ARCHITECTURAL PRODUCTS IS ONLY RESPONSIBLE FOR THE THERMAL EXPANSION OF THE SUBFRAMING OF THE ADJUSTABLE SYSTEM. THE CLADDING MANUFACTURER IS RESPONSIBLE FOR HANDLING THERMAL EXPANSION OF THE CLADDING AS WELL AS THERMAL EXPANSION COMPATIBILITY WITH THE ADJUSTABLE SUBFRAMING.

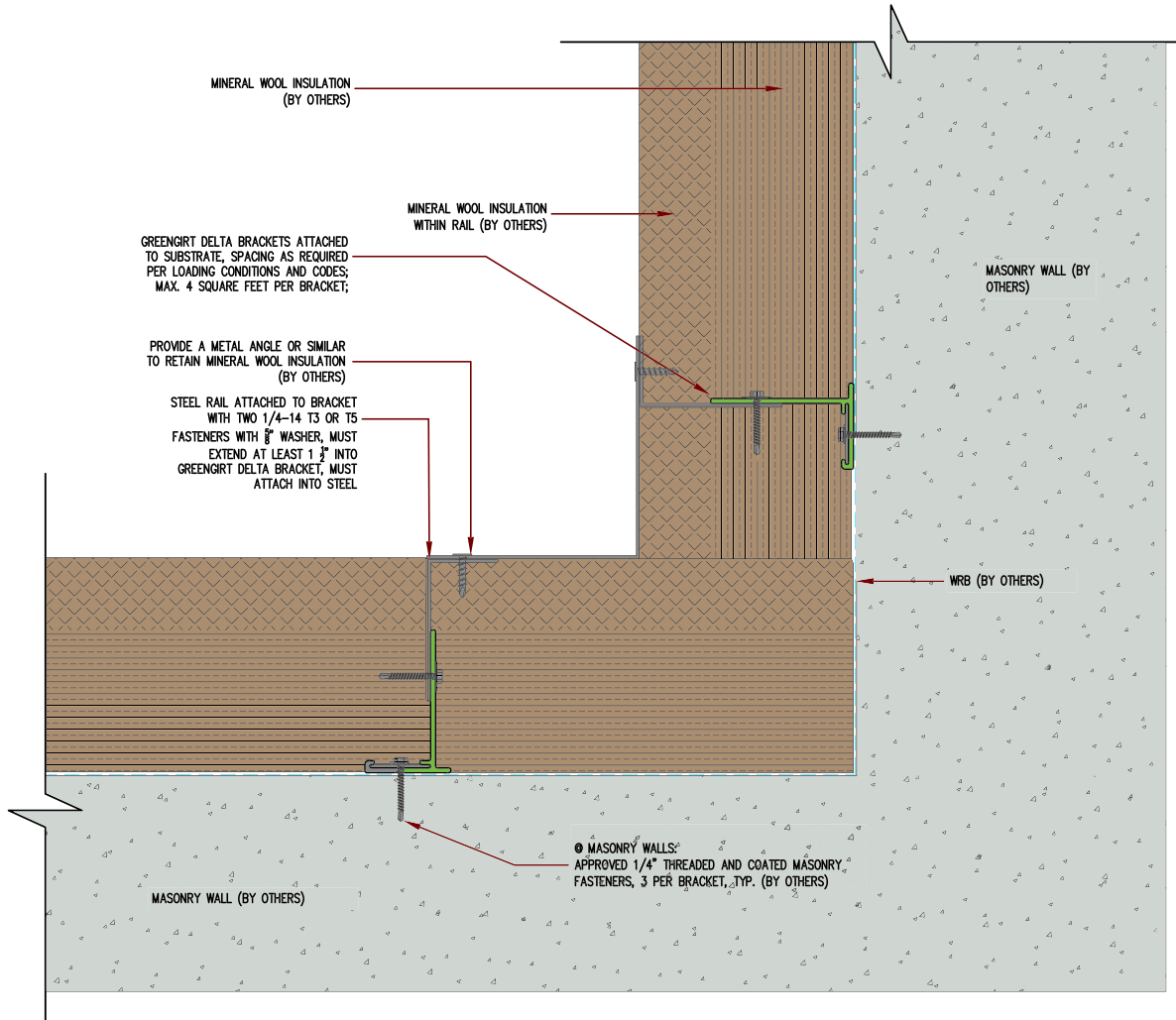

GreenGirt Delta™
COMPOSITE METAL HYBRID ADJUSTABLE SYSTEM

GreenGirt.com

(269) 355-1818

SUBSTRATE: MASONRY	INSULATION: MINERAL WOOL
CLADDING:	DATE
GREENGIRT DELTA BRACKET SIZE: 300 / 3"	ORIENTATION: VERTICAL Z-BRACKET

INSIDE CORNER DETAIL

NOT TO SCALE

4

13C. Masonry - Outside Corner Detail



NOTE: DETAILS ARE PROVIDED FOR INFORMATION ONLY, AND ARE SUBJECT TO CHANGE WITHOUT NOTICE. SPECIFIC PROJECT ENGINEERING BY OTHERS WILL ADDRESS ATTACHMENT SPACING, ORIENTATION AND LOADING. CONTACT ADVANCED ARCHITECTURAL PRODUCTS FOR FURTHER DETAILS, AND TO INQUIRE ABOUT UPDATES AND REVISIONS. ADVANCED ARCHITECTURAL PRODUCTS IS ONLY RESPONSIBLE FOR THE THERMAL EXPANSION OF THE SUBFRAMING OF THE ADJUSTABLE SYSTEM. THE CLADDING MANUFACTURER IS RESPONSIBLE FOR HANDLING THERMAL EXPANSION OF THE CLADDING AS WELL AS THERMAL EXPANSION COMPATIBILITY WITH THE ADJUSTABLE SUBFRAMING.

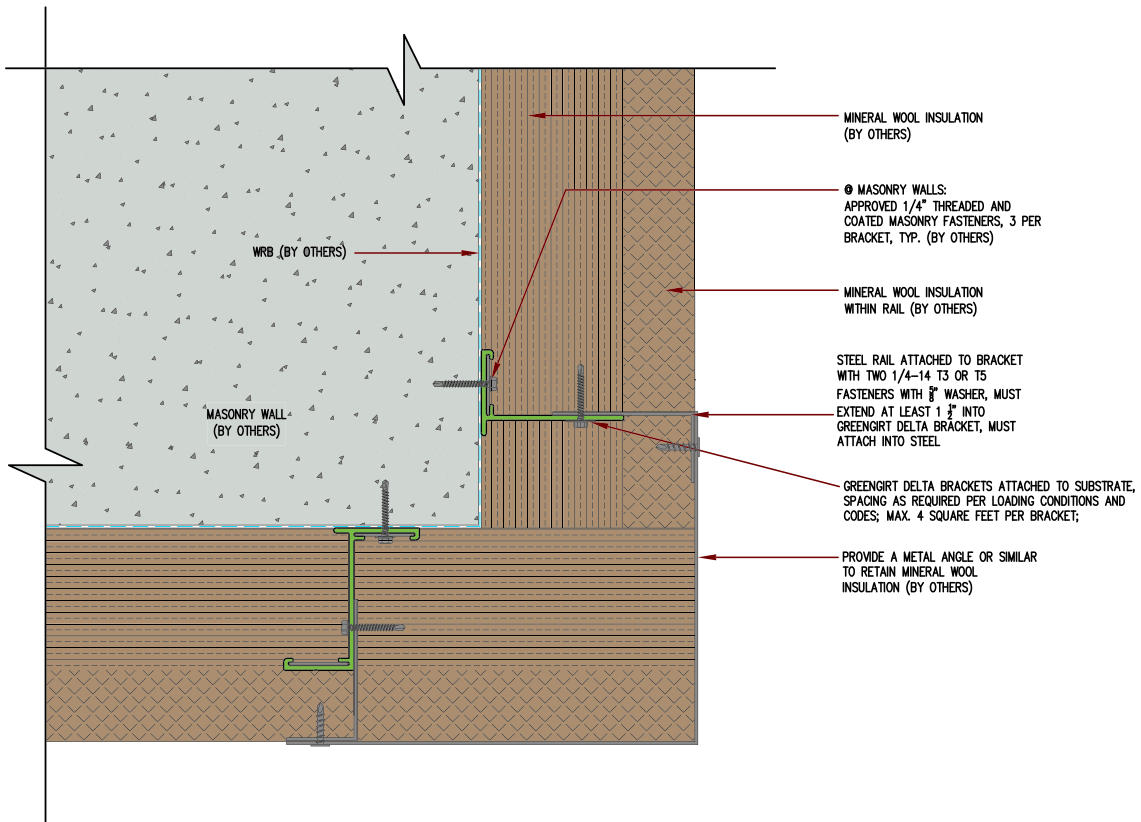

GreenGirt.com

(269) 355-1818

SUBSTRATE: MASONRY	INSULATION: MINERAL WOOL
CLADDING:	DATE
GREENGIRT DELTA BRACKET SIZE: 300 / 3"	ORIENTATION: VERTICAL Z-BRACKET

OUTSIDE CORNER DETAIL

NOT TO SCALE

5

13D. Masonry - Header Detail



NOTE: DETAILS ARE PROVIDED FOR INFORMATION ONLY, AND ARE SUBJECT TO CHANGE WITHOUT NOTICE. SPECIFIC PROJECT ENGINEERING BY OTHERS WILL ADDRESS ATTACHMENT SPACING, ORIENTATION AND LOADING. CONTACT ADVANCED ARCHITECTURAL PRODUCTS FOR FURTHER DETAILS, AND TO INQUIRE ABOUT UPDATES AND REVISIONS. ADVANCED ARCHITECTURAL PRODUCTS IS ONLY RESPONSIBLE FOR THE THERMAL EXPANSION OF THE SUBFRAMING OF THE ADJUSTABLE SYSTEM. THE CLADDING MANUFACTURER IS RESPONSIBLE FOR HANDLING THERMAL EXPANSION OF THE CLADDING AS WELL AS THERMAL EXPANSION COMPATIBILITY WITH THE ADJUSTABLE SUBFRAMING.

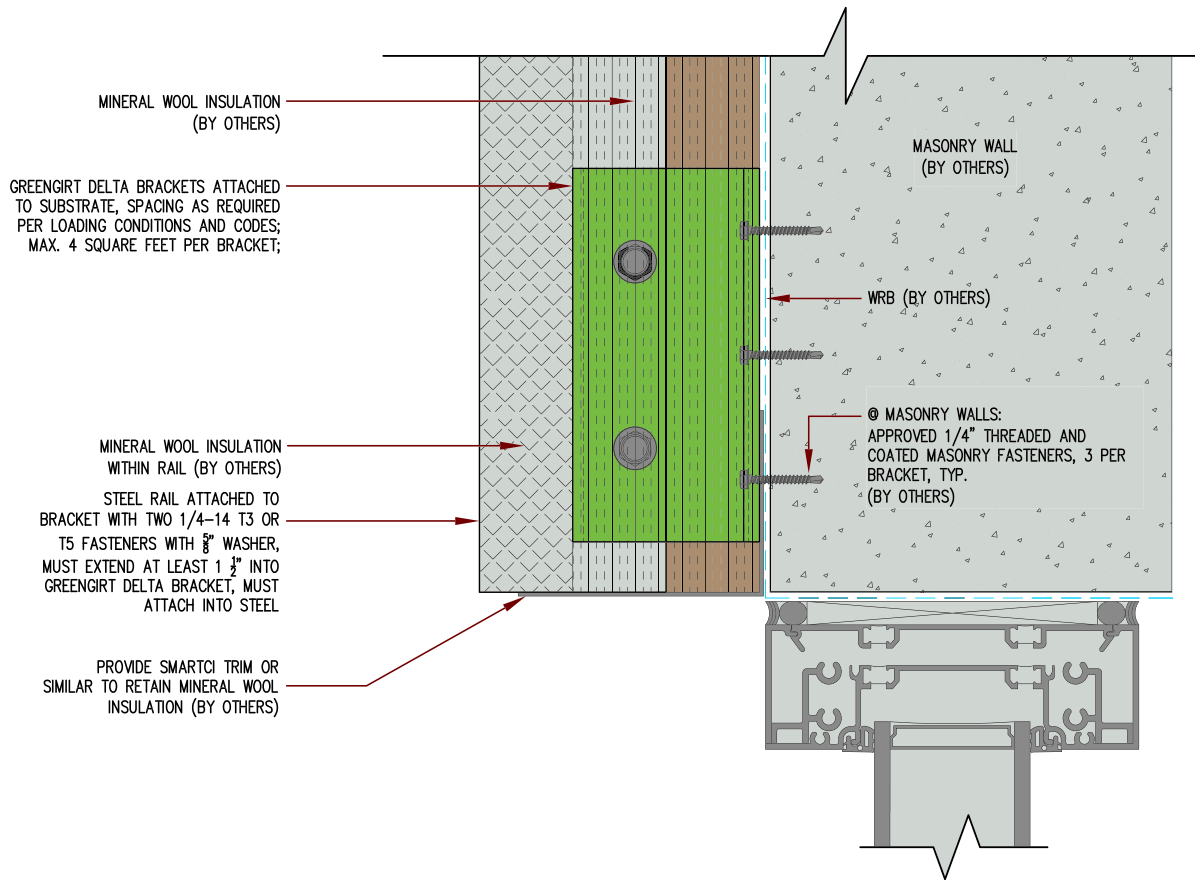

GreenGirt Delta™
COMPOSITE METAL HYBRID ADJUSTABLE SYSTEM

GreenGirt.com

(269) 355-1818

SUBSTRATE: MASONRY

CLADDING:

GREENGIRT DELTA BRACKET SIZE: 300 / 3"

INSULATION: MINERAL WOOL

DATE

ORIENTATION: VERTICAL Z-BRACKET

HEADER DETAIL

NOT TO SCALE

6

13E. Masonry - Jamb Detail



NOTE: DETAILS ARE PROVIDED FOR INFORMATION ONLY, AND ARE SUBJECT TO CHANGE WITHOUT NOTICE. SPECIFIC PROJECT ENGINEERING BY OTHERS WILL ADDRESS ATTACHMENT SPACING, ORIENTATION AND LOADING. CONTACT ADVANCED ARCHITECTURAL PRODUCTS FOR FURTHER DETAILS, AND TO INQUIRE ABOUT UPDATES AND REVISIONS. ADVANCED ARCHITECTURAL PRODUCTS IS ONLY RESPONSIBLE FOR THE THERMAL EXPANSION OF THE SUBFRAMING OF THE ADJUSTABLE SYSTEM. THE CLADDING MANUFACTURER IS RESPONSIBLE FOR HANDLING THERMAL EXPANSION OF THE CLADDING AS WELL AS THERMAL EXPANSION COMPATIBILITY WITH THE ADJUSTABLE SUBFRAMING.

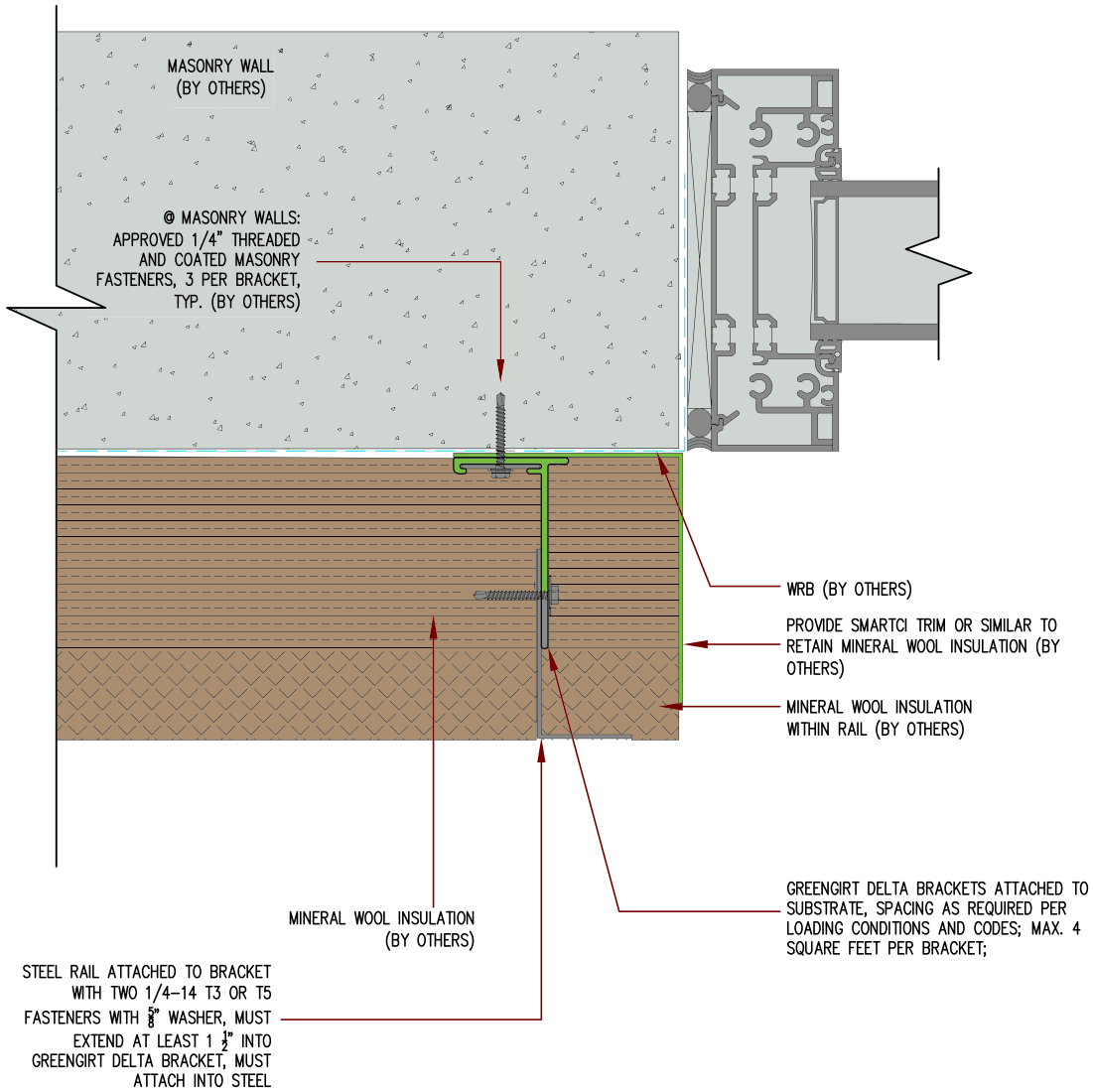

GreenGirt Delta™
COMPOSITE METAL HYBRID ADJUSTABLE SYSTEM

GreenGirt.com

(269) 355-1818

SUBSTRATE: MASONRY

INSULATION: MINERAL WOOL

CLADDING:

DATE

GREENGIRT DELTA BRACKET SIZE: 300 / 3"

ORIENTATION: VERTICAL Z-BRACKET

JAMB DETAIL

NOT TO SCALE

7

13F. Masonry - Sill Detail



NOTE: DETAILS ARE PROVIDED FOR INFORMATION ONLY, AND ARE SUBJECT TO CHANGE WITHOUT NOTICE. SPECIFIC PROJECT ENGINEERING BY OTHERS WILL ADDRESS ATTACHMENT SPACING, ORIENTATION AND LOADING. CONTACT ADVANCED ARCHITECTURAL PRODUCTS FOR FURTHER DETAILS, AND TO INQUIRE ABOUT UPDATES AND REVISIONS. ADVANCED ARCHITECTURAL PRODUCTS IS ONLY RESPONSIBLE FOR THE THERMAL EXPANSION OF THE SUBFRAMING OF THE ADJUSTABLE SYSTEM. THE CLADDING MANUFACTURER IS RESPONSIBLE FOR HANDLING THERMAL EXPANSION OF THE CLADDING AS WELL AS THERMAL EXPANSION COMPATIBILITY WITH THE ADJUSTABLE SUBFRAMING.

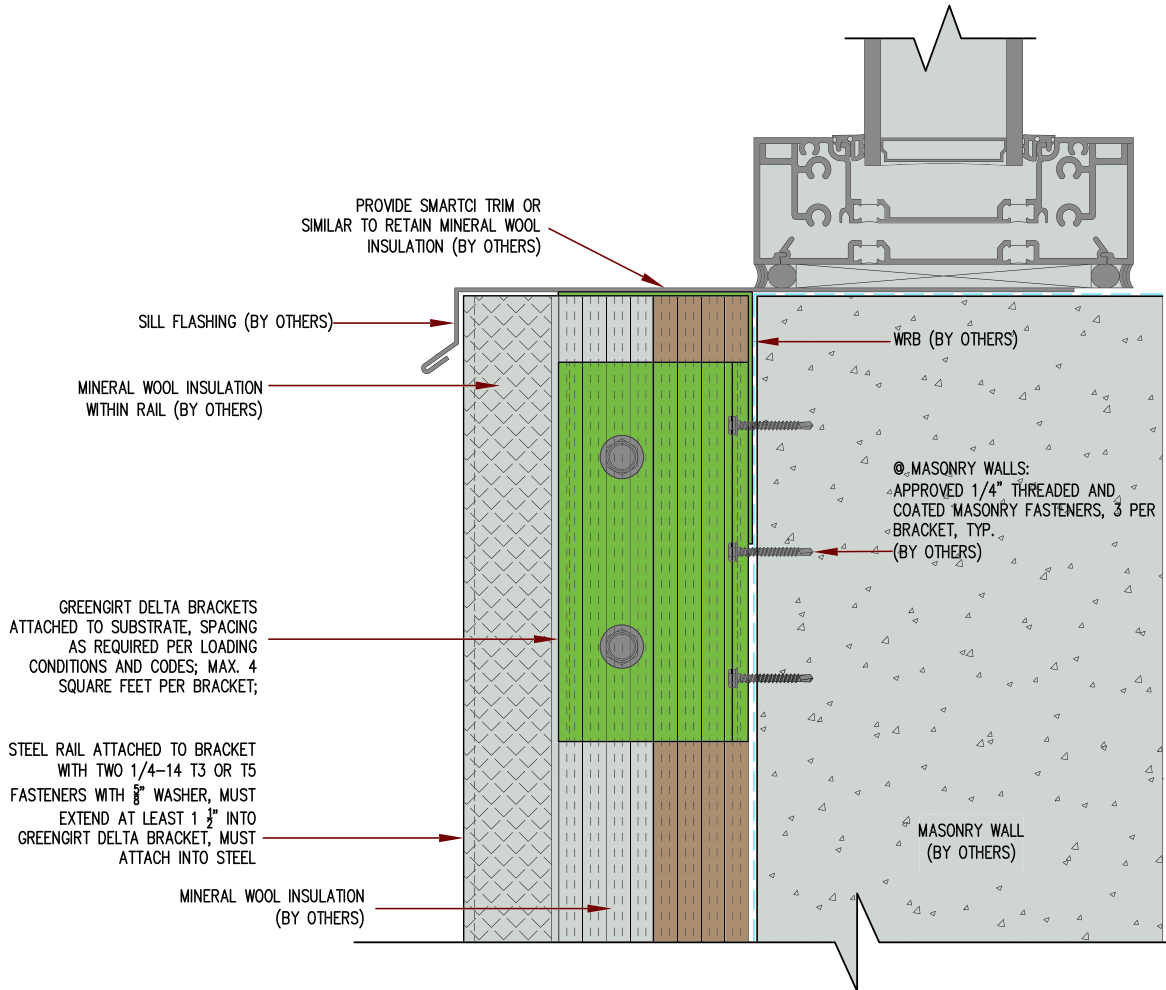

 <p>COMPOSITE METAL HYBRID ADJUSTABLE SYSTEM</p> <p>GreenGirt.com (269) 355-1818</p>	SUBSTRATE: MASONRY	INSULATION: MINERAL WOOL
	CLADDING:	DATE
	GREENGIRT DELTA BRACKET SIZE: 300 / 3"	ORIENTATION: VERTICAL Z-BRACKET
<p>SILL DETAIL</p> <p>NOT TO SCALE</p>		

13G. Masonry - Delta Slider with Steel L-Rail



NOTE: DETAILS ARE PROVIDED FOR INFORMATION ONLY, AND ARE SUBJECT TO CHANGE WITHOUT NOTICE. SPECIFIC PROJECT ENGINEERING BY OTHERS WILL ADDRESS ATTACHMENT SPACING, ORIENTATION AND LOADING. CONTACT ADVANCED ARCHITECTURAL PRODUCTS FOR FURTHER DETAILS, AND TO INQUIRE ABOUT UPDATES AND REVISIONS. ADVANCED ARCHITECTURAL PRODUCTS IS ONLY RESPONSIBLE FOR THE THERMAL EXPANSION OF THE SUBFRAMING OF THE ADJUSTABLE SYSTEM. THE CLADDING MANUFACTURER IS RESPONSIBLE FOR HANDLING THERMAL EXPANSION OF THE CLADDING AS WELL AS THERMAL EXPANSION COMPATIBILITY WITH THE ADJUSTABLE SUBFRAMING.

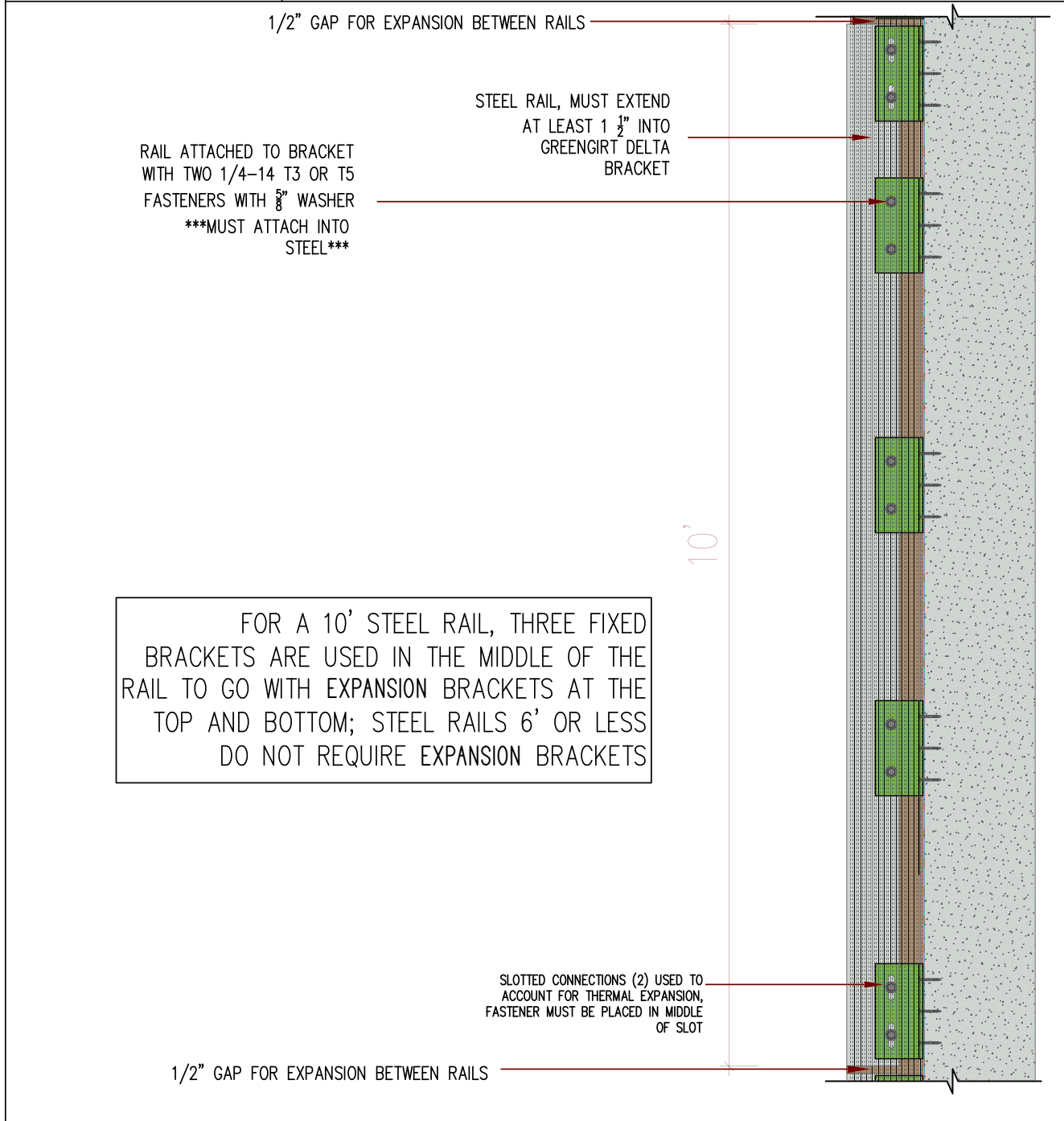

<p>COMPOSITE METAL HYBRID ADJUSTABLE SYSTEM</p> <p>GreenGirt.com (269) 355-1818</p>	SUBSTRATE: MASONRY	INSULATION: MINERAL WOOL
	CLADDING:	DATE
	GREENGIRT DELTA BRACKET SIZE: 300 / 3"	ORIENTATION: VERTICAL Z-BRACKET
<h2>DELTA W STEEL</h2> <p>NOT TO SCALE</p>		

13H. Masonry - Delta Slider with Aluminum L-Rail



NOTE: DETAILS ARE PROVIDED FOR INFORMATION ONLY, AND ARE SUBJECT TO CHANGE WITHOUT NOTICE. SPECIFIC PROJECT ENGINEERING BY OTHERS WILL ADDRESS ATTACHMENT SPACING, ORIENTATION AND LOADING. CONTACT ADVANCED ARCHITECTURAL PRODUCTS FOR FURTHER DETAILS, AND TO INQUIRE ABOUT UPDATES AND REVISIONS. ADVANCED ARCHITECTURAL PRODUCTS IS ONLY RESPONSIBLE FOR THE THERMAL EXPANSION OF THE SUBFRAMING OF THE ADJUSTABLE SYSTEM. THE CLADDING MANUFACTURER IS RESPONSIBLE FOR HANDLING THERMAL EXPANSION OF THE CLADDING AS WELL AS THERMAL EXPANSION COMPATIBILITY WITH THE ADJUSTABLE SUBFRAMING.

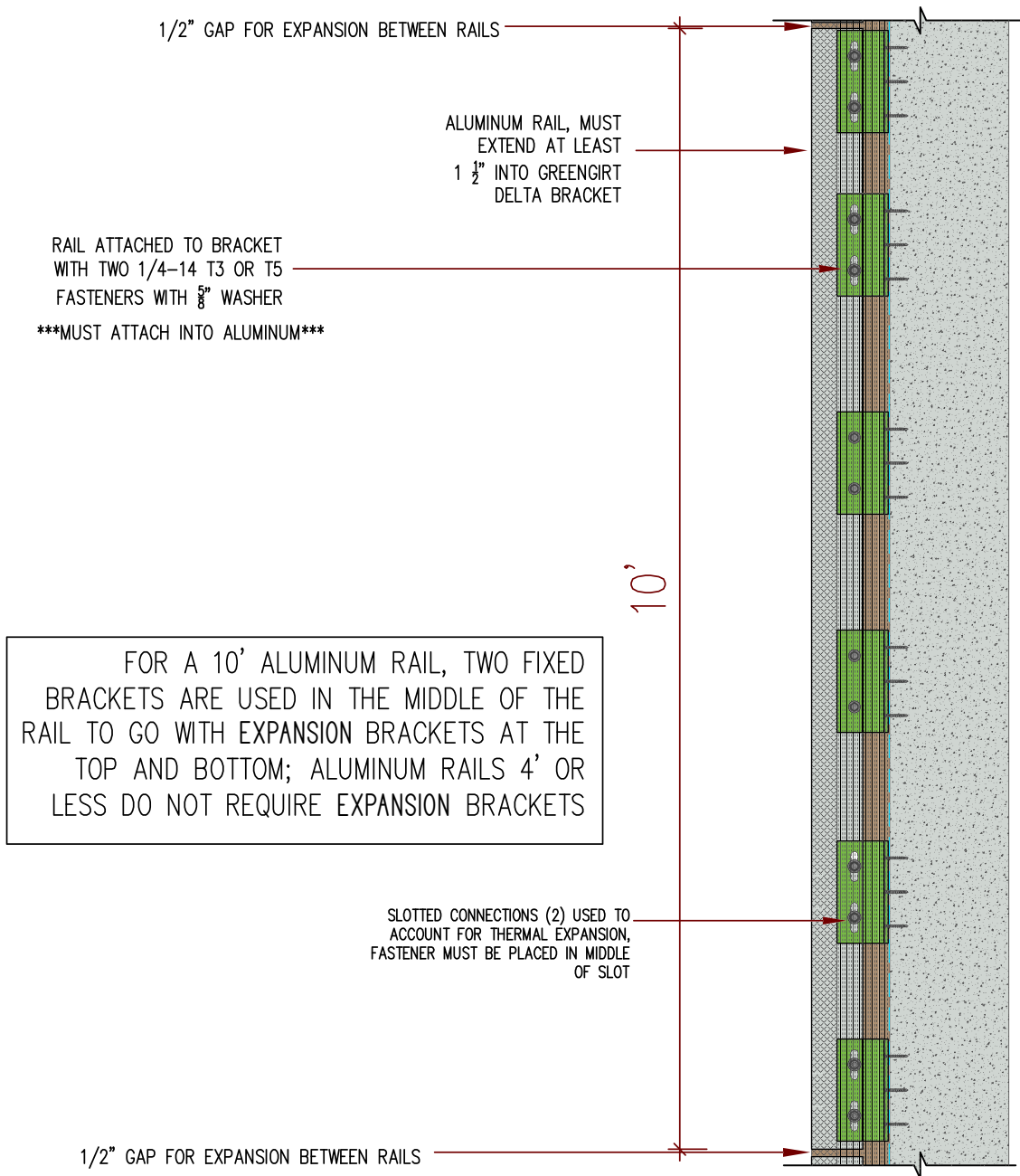

GreenGirt Delta™
COMPOSITE METAL HYBRID ADJUSTABLE SYSTEM

GreenGirt.com

(269) 355-1818

SUBSTRATE: **MASONRY**

CLADDING:

GREENGIRT DELTA BRACKET SIZE: 300 / 3"

INSULATION: MINERAL WOOL

DATE

ORIENTATION: VERTICAL Z-BRACKET

DELTA W ALUMINUM

NOT TO SCALE

13I. Masonry - Delta Slider (Bottom of L-Rail)



NOTE: DETAILS ARE PROVIDED FOR INFORMATION ONLY, AND ARE SUBJECT TO CHANGE WITHOUT NOTICE. SPECIFIC PROJECT ENGINEERING BY OTHERS WILL ADDRESS ATTACHMENT SPACING, ORIENTATION AND LOADING. CONTACT ADVANCED ARCHITECTURAL PRODUCTS FOR FURTHER DETAILS, AND TO INQUIRE ABOUT UPDATES AND REVISIONS. ADVANCED ARCHITECTURAL PRODUCTS IS ONLY RESPONSIBLE FOR THE THERMAL EXPANSION OF THE SUBFRAMING OF THE ADJUSTABLE SYSTEM. THE CLADDING MANUFACTURER IS RESPONSIBLE FOR HANDLING THERMAL EXPANSION OF THE CLADDING AS WELL AS THERMAL EXPANSION COMPATIBILITY WITH THE ADJUSTABLE SUBFRAMING.

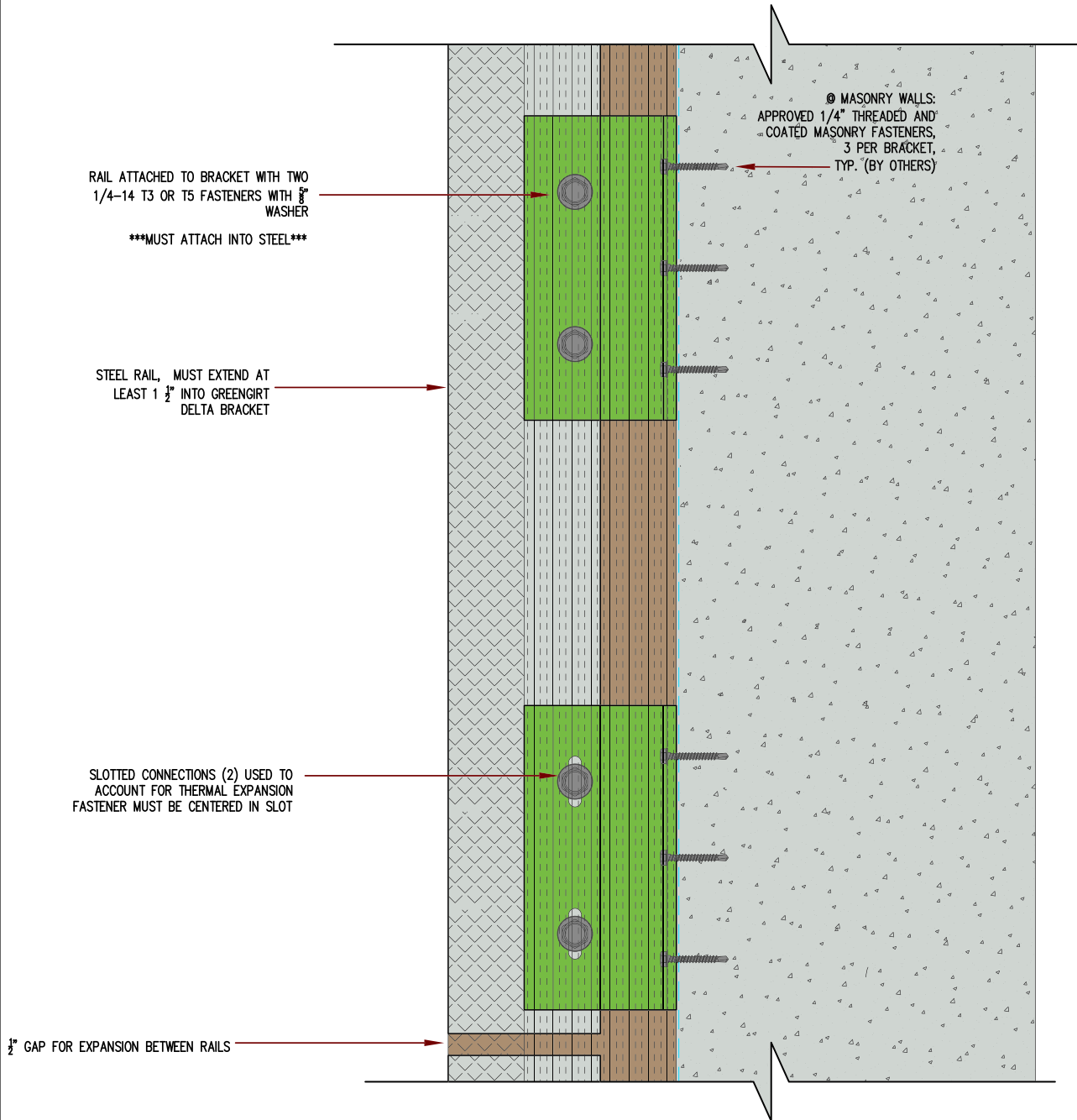

<p>COMPOSITE METAL HYBRID ADJUSTABLE SYSTEM</p> <p>GreenGirt.com (269) 355-1818</p>	SUBSTRATE: MASONRY	INSULATION: MINERAL WOOL
	CLADDING:	DATE
	GREENGIRT DELTA BRACKET SIZE: 300 / 3"	ORIENTATION: VERTICAL Z-BRACKET
	<h2>DELTA SLIDER (BTM OF RAIL)</h2> <p>NOT TO SCALE</p>	

13J. Masonry - Delta Slider (Floor Joint)



NOTE: DETAILS ARE PROVIDED FOR INFORMATION ONLY, AND ARE SUBJECT TO CHANGE WITHOUT NOTICE. SPECIFIC PROJECT ENGINEERING BY OTHERS WILL ADDRESS ATTACHMENT SPACING, ORIENTATION AND LOADING. CONTACT ADVANCED ARCHITECTURAL PRODUCTS FOR FURTHER DETAILS, AND TO INQUIRE ABOUT UPDATES AND REVISIONS. ADVANCED ARCHITECTURAL PRODUCTS IS ONLY RESPONSIBLE FOR THE THERMAL EXPANSION OF THE SUBFRAMING OF THE ADJUSTABLE SYSTEM. THE CLADDING MANUFACTURER IS RESPONSIBLE FOR HANDLING THERMAL EXPANSION OF THE CLADDING AS WELL AS THERMAL EXPANSION COMPATIBILITY WITH THE ADJUSTABLE SUBFRAMING.

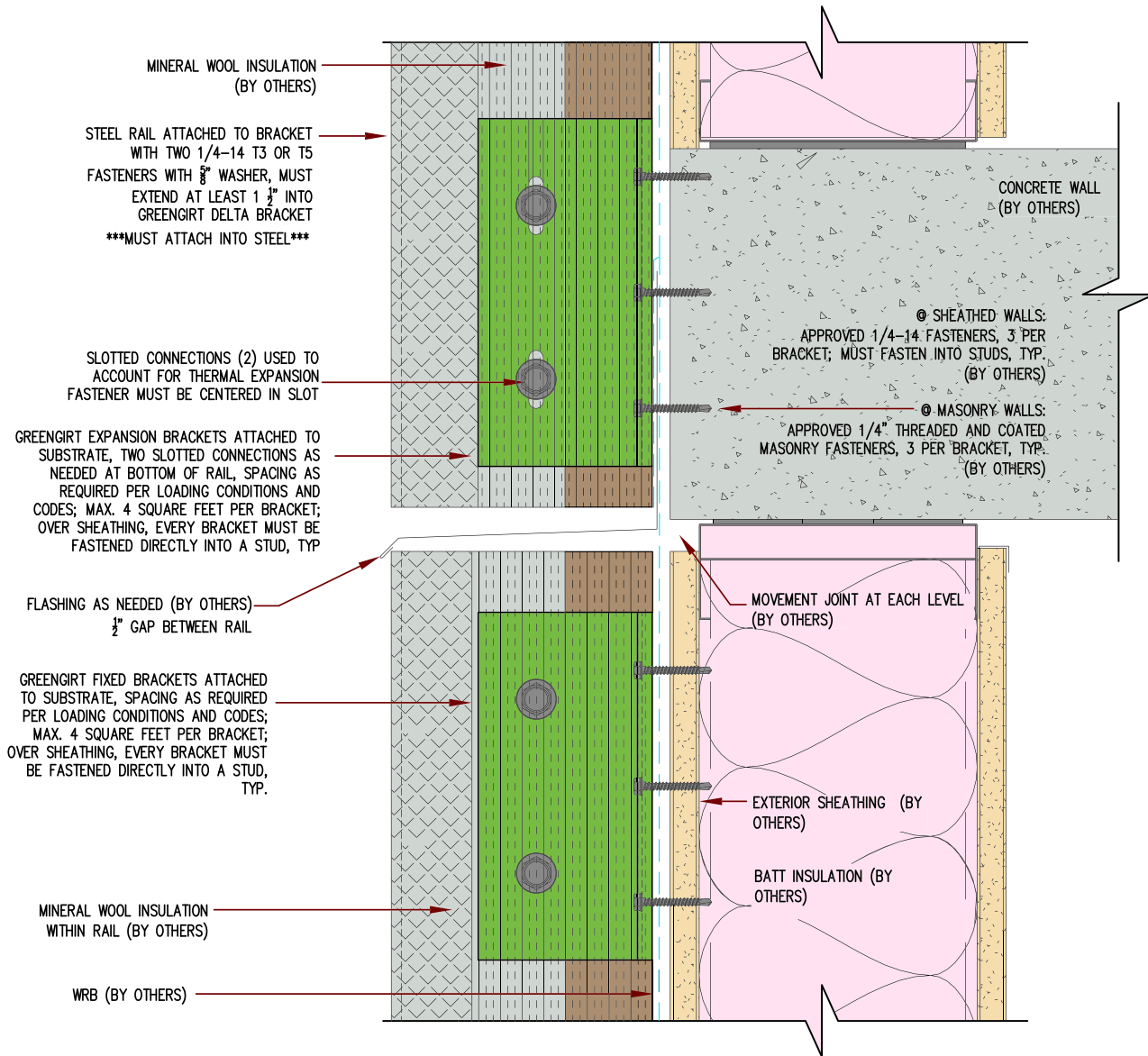

GreenGirt Delta™
COMPOSITE METAL HYBRID ADJUSTABLE SYSTEM

GreenGirt.com

(269) 355-1818

SUBSTRATE: MASONRY	INSULATION: MINERAL WOOL
CLADDING:	DATE
GREENGIRT DELTA BRACKET SIZE: 300 / 3"	ORIENTATION: VERTICAL Z-BRACKET

DELTA SLIDER (FLOOR JOINT)

NOT TO SCALE

14A. Construction Details on Studs (Vertical) - Wall Section

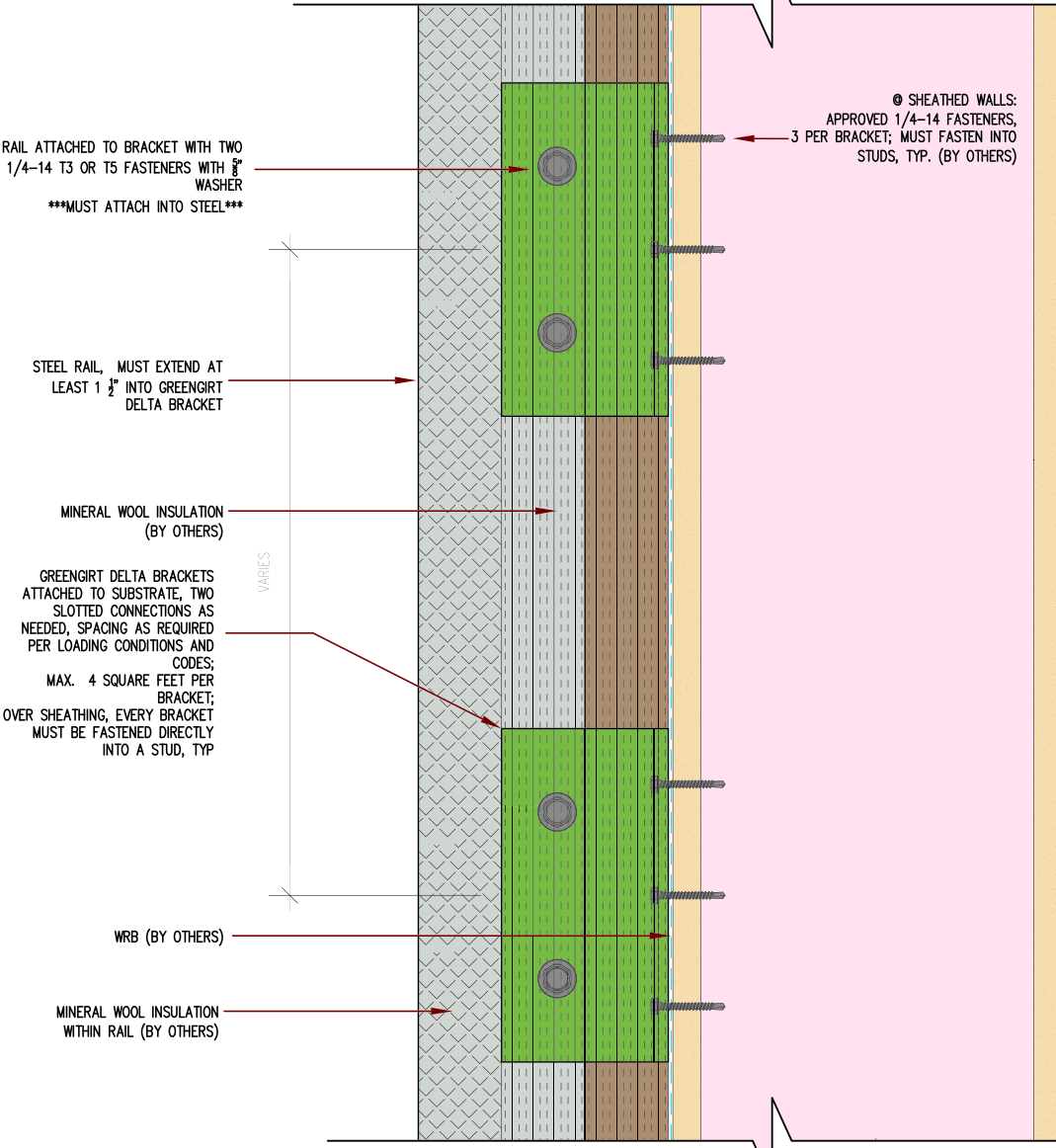
 <p>ADVANCED ARCHITECTURAL PRODUCTS</p>	<p>NOTE: DETAILS ARE PROVIDED FOR INFORMATION ONLY, AND ARE SUBJECT TO CHANGE WITHOUT NOTICE. SPECIFIC PROJECT ENGINEERING BY OTHERS WILL ADDRESS ATTACHMENT SPACING, ORIENTATION AND LOADING. CONTACT ADVANCED ARCHITECTURAL PRODUCTS FOR FURTHER DETAILS, AND TO INQUIRE ABOUT UPDATES AND REVISIONS. ADVANCED ARCHITECTURAL PRODUCTS IS ONLY RESPONSIBLE FOR THE THERMAL EXPANSION OF THE SUBFRAMING OF THE ADJUSTABLE SYSTEM. THE CLADDING MANUFACTURER IS RESPONSIBLE FOR HANDLING THERMAL EXPANSION OF THE CLADDING AS WELL AS THERMAL EXPANSION COMPATIBILITY WITH THE ADJUSTABLE SUBFRAMING.</p>										
											
<p>RAIL ATTACHED TO BRACKET WITH TWO 1/4-14 T3 OR T5 FASTENERS WITH 3/8" WASHER ***MUST ATTACH INTO STEEL***</p> <p>STEEL RAIL, MUST EXTEND AT LEAST 1 1/2" INTO GREENGIRT DELTA BRACKET</p> <p>MINERAL WOOL INSULATION (BY OTHERS)</p> <p>GREENGIRT DELTA BRACKETS ATTACHED TO SUBSTRATE, TWO SLOTTED CONNECTIONS AS NEEDED, SPACING AS REQUIRED PER LOADING CONDITIONS AND CODES; MAX. 4 SQUARE FEET PER BRACKET; OVER SHEATHING, EVERY BRACKET MUST BE FASTENED DIRECTLY INTO A STUD, TYP</p> <p>WRB (BY OTHERS)</p> <p>MINERAL WOOL INSULATION WITHIN RAIL (BY OTHERS)</p>	<p>Ⓞ SHEATHED WALLS: APPROVED 1/4-14 FASTENERS, 3 PER BRACKET; MUST FASTEN INTO STUDS, TYP. (BY OTHERS)</p>										
<p style="font-size: x-small;">GreenGirt Delta™ COMPOSITE METAL HYBRID ADJUSTABLE SYSTEM</p> <p style="font-size: x-small;">GreenGirt.com (269) 355-1818</p>	<table border="1" style="width: 100%; border-collapse: collapse; font-size: x-small;"> <tr> <td style="width: 50%;">SUBSTRATE: SHEATHING W/ METAL STUD</td> <td style="width: 50%;">INSULATION: MINERAL WOOL</td> </tr> <tr> <td>CLADDING:</td> <td>DATE</td> </tr> <tr> <td>GREENGIRT DELTA BRACKET SIZE: 300 / 3"</td> <td>ORIENTATION: VERTICAL Z-BRACKET</td> </tr> <tr> <td colspan="2" style="text-align: center; font-size: 2em;">3" STEEL RAIL WITH 3" DELTA</td> </tr> <tr> <td colspan="2" style="text-align: center;">NOT TO SCALE</td> </tr> </table>	SUBSTRATE: SHEATHING W/ METAL STUD	INSULATION: MINERAL WOOL	CLADDING:	DATE	GREENGIRT DELTA BRACKET SIZE: 300 / 3"	ORIENTATION: VERTICAL Z-BRACKET	3" STEEL RAIL WITH 3" DELTA		NOT TO SCALE	
SUBSTRATE: SHEATHING W/ METAL STUD	INSULATION: MINERAL WOOL										
CLADDING:	DATE										
GREENGIRT DELTA BRACKET SIZE: 300 / 3"	ORIENTATION: VERTICAL Z-BRACKET										
3" STEEL RAIL WITH 3" DELTA											
NOT TO SCALE											

14B. Studs - Inside Corner Detail



NOTE: DETAILS ARE PROVIDED FOR INFORMATION ONLY, AND ARE SUBJECT TO CHANGE WITHOUT NOTICE. SPECIFIC PROJECT ENGINEERING BY OTHERS WILL ADDRESS ATTACHMENT SPACING, ORIENTATION AND LOADING. CONTACT ADVANCED ARCHITECTURAL PRODUCTS FOR FURTHER DETAILS, AND TO INQUIRE ABOUT UPDATES AND REVISIONS. ADVANCED ARCHITECTURAL PRODUCTS IS ONLY RESPONSIBLE FOR THE THERMAL EXPANSION OF THE SUBFRAMING OF THE ADJUSTABLE SYSTEM. THE CLADDING MANUFACTURER IS RESPONSIBLE FOR HANDLING THERMAL EXPANSION OF THE CLADDING AS WELL AS THERMAL EXPANSION COMPATIBILITY WITH THE ADJUSTABLE SUBFRAMING.

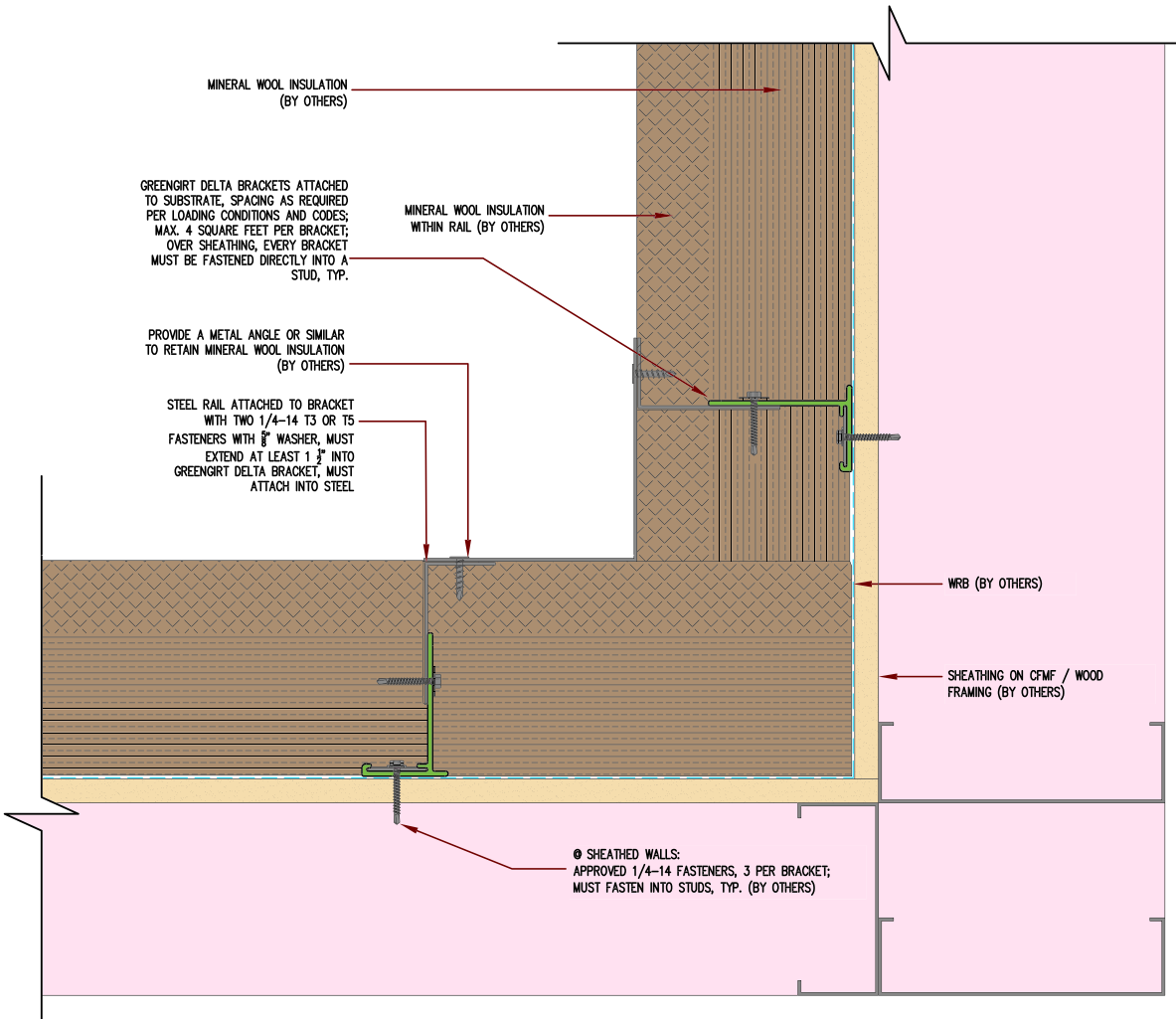

GreenGirt Delta™
COMPOSITE METAL HYBRID ADJUSTABLE SYSTEM

GreenGirt.com

(269) 355-1818

SUBSTRATE: SHEATHING W/ METAL STUD

INSULATION: MINERAL WOOL

CLADDING:

DATE

GREENGIRT DELTA BRACKET SIZE: 300 / 3"

ORIENTATION: VERTICAL Z-BRACKET

INSIDE CORNER DETAIL

NOT TO SCALE

4

14C. Studs - Outside Corner Detail

gap™ ADVANCED ARCHITECTURAL PRODUCTS

NOTE: DETAILS ARE PROVIDED FOR INFORMATION ONLY, AND ARE SUBJECT TO CHANGE WITHOUT NOTICE. SPECIFIC PROJECT ENGINEERING BY OTHERS WILL ADDRESS ATTACHMENT SPACING, ORIENTATION AND LOADING. CONTACT ADVANCED ARCHITECTURAL PRODUCTS FOR FURTHER DETAILS, AND TO INQUIRE ABOUT UPDATES AND REVISIONS. ADVANCED ARCHITECTURAL PRODUCTS IS ONLY RESPONSIBLE FOR THE THERMAL EXPANSION OF THE SUBFRAMING OF THE ADJUSTABLE SYSTEM. THE CLADDING MANUFACTURER IS RESPONSIBLE FOR HANDLING THERMAL EXPANSION OF THE CLADDING AS WELL AS THERMAL EXPANSION COMPATIBILITY WITH THE ADJUSTABLE SUBFRAMING.

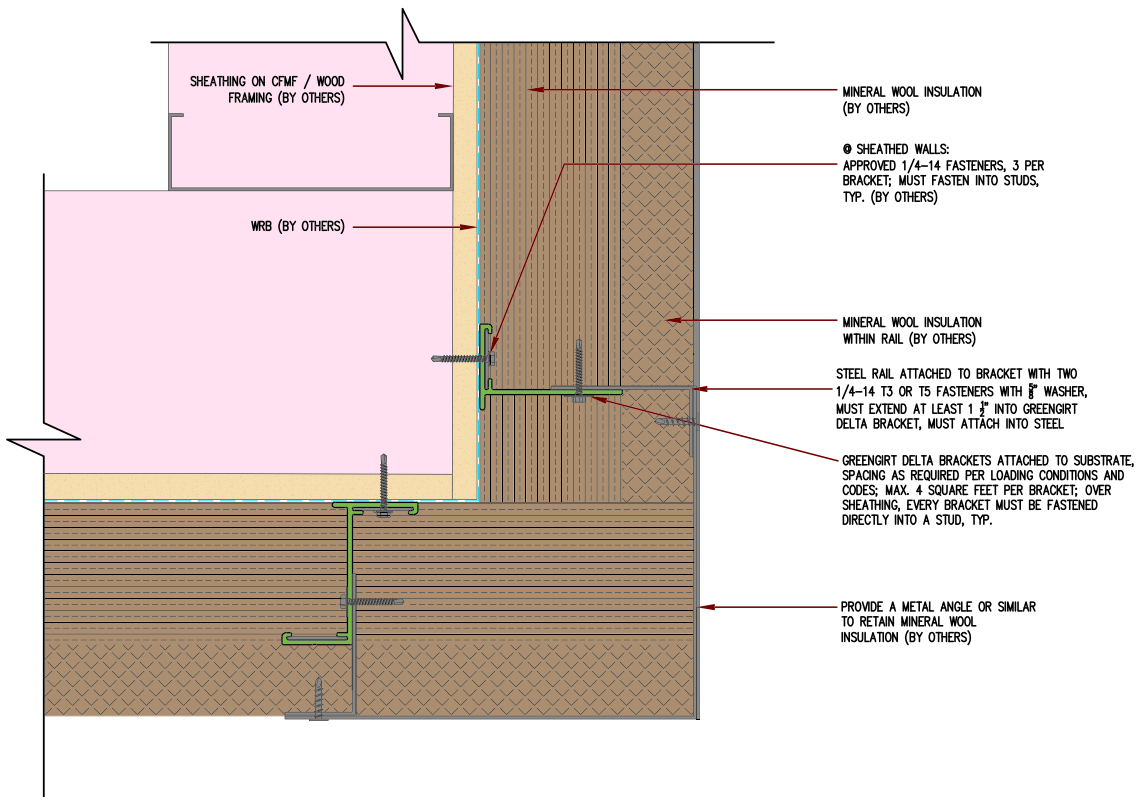

<p>GreenGirt Delta™ COMPOSITE METAL HYBRID ADJUSTABLE SYSTEM</p> <p>GreenGirt.com (269) 355-1818</p>	SUBSTRATE: SHEATHING W/ METAL STUD	INSULATION: MINERAL WOOL
	CLADDING:	DATE
	GREENGIRT DELTA BRACKET SIZE: 300 / 3"	ORIENTATION: VERTICAL Z-BRACKET
<p>OUTSIDE CORNER DETAIL</p> <p>NOT TO SCALE</p>		5

14D. Studs - Header Detail



NOTE: DETAILS ARE PROVIDED FOR INFORMATION ONLY, AND ARE SUBJECT TO CHANGE WITHOUT NOTICE. SPECIFIC PROJECT ENGINEERING BY OTHERS WILL ADDRESS ATTACHMENT SPACING, ORIENTATION AND LOADING. CONTACT ADVANCED ARCHITECTURAL PRODUCTS FOR FURTHER DETAILS, AND TO INQUIRE ABOUT UPDATES AND REVISIONS. ADVANCED ARCHITECTURAL PRODUCTS IS ONLY RESPONSIBLE FOR THE THERMAL EXPANSION OF THE SUBFRAMING OF THE ADJUSTABLE SYSTEM. THE CLADDING MANUFACTURER IS RESPONSIBLE FOR HANDLING THERMAL EXPANSION OF THE CLADDING AS WELL AS THERMAL EXPANSION COMPATIBILITY WITH THE ADJUSTABLE SUBFRAMING.

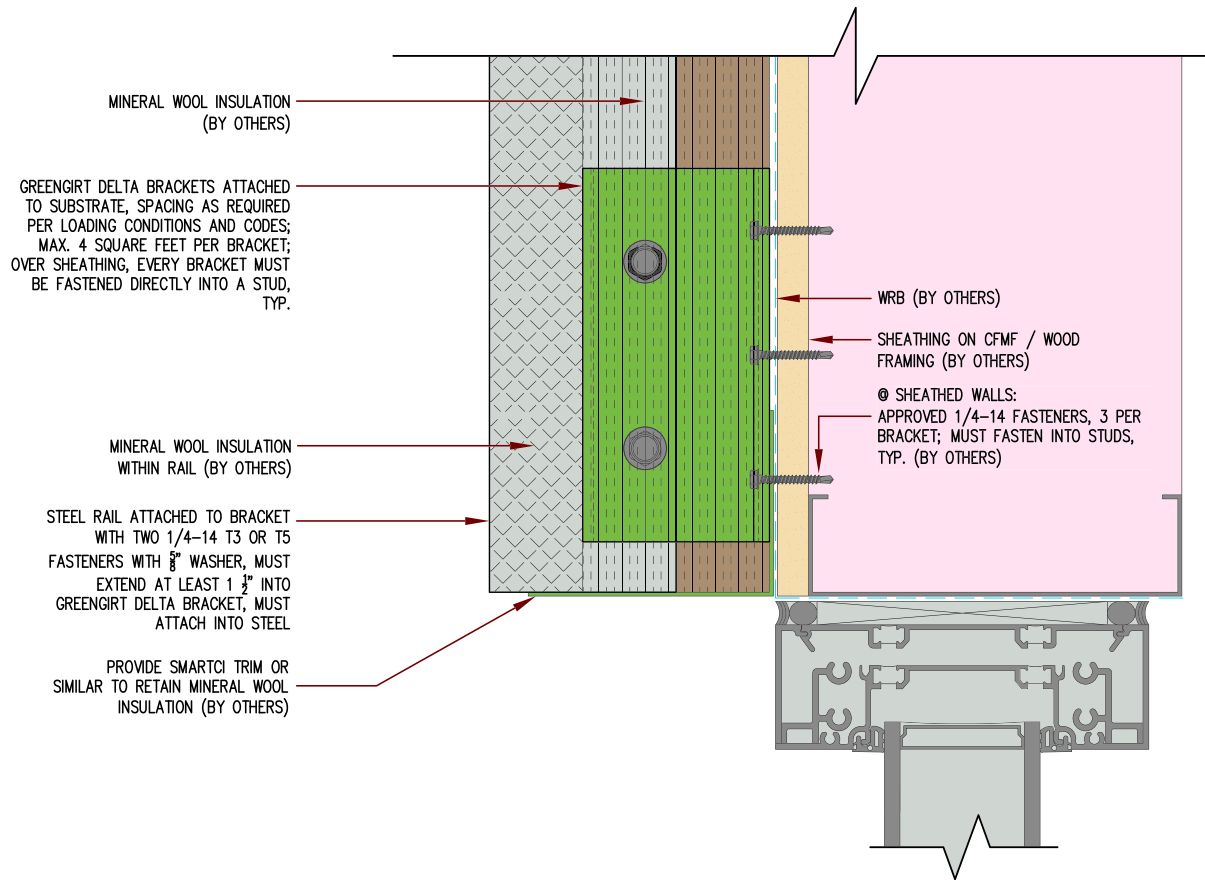

GreenGirt Delta™
COMPOSITE METAL HYBRID ADJUSTABLE SYSTEM

GreenGirt.com

(269) 355-1818

SUBSTRATE: SHEATHING W/ METAL STUD

INSULATION: MINERAL WOOL

CLADDING:

DATE

GREENGIRT DELTA BRACKET SIZE: 300 / 3"

ORIENTATION: VERTICAL Z-BRACKET

HEADER DETAIL

NOT TO SCALE

6

14E. Studs - Jamb Detail



NOTE: DETAILS ARE PROVIDED FOR INFORMATION ONLY, AND ARE SUBJECT TO CHANGE WITHOUT NOTICE. SPECIFIC PROJECT ENGINEERING BY OTHERS WILL ADDRESS ATTACHMENT SPACING, ORIENTATION AND LOADING. CONTACT ADVANCED ARCHITECTURAL PRODUCTS FOR FURTHER DETAILS, AND TO INQUIRE ABOUT UPDATES AND REVISIONS. ADVANCED ARCHITECTURAL PRODUCTS IS ONLY RESPONSIBLE FOR THE THERMAL EXPANSION OF THE SUBFRAMING OF THE ADJUSTABLE SYSTEM. THE CLADDING MANUFACTURER IS RESPONSIBLE FOR HANDLING THERMAL EXPANSION OF THE CLADDING AS WELL AS THERMAL EXPANSION COMPATIBILITY WITH THE ADJUSTABLE SUBFRAMING.

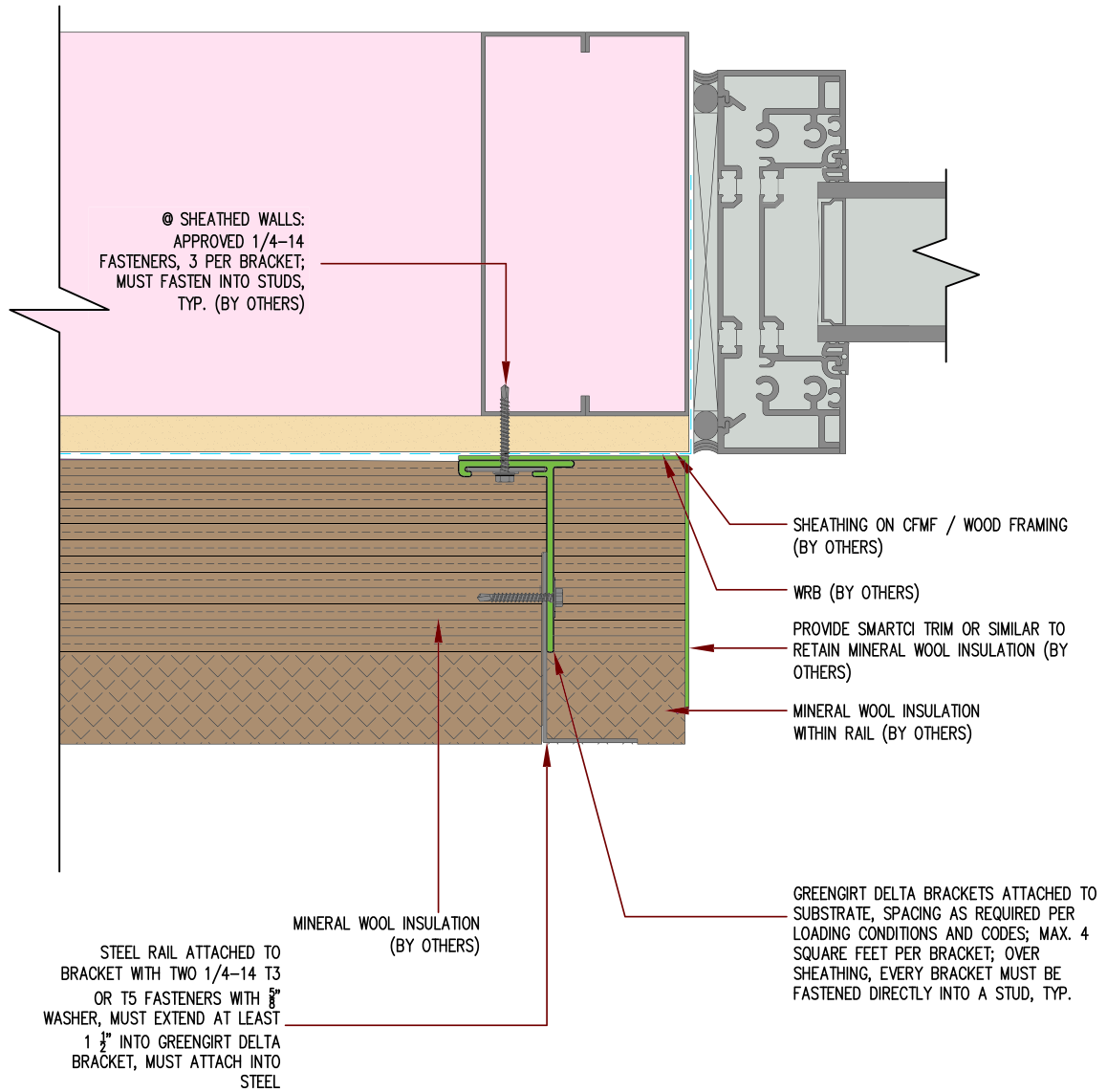

GreenGirt.com

(269) 355-1818

SUBSTRATE: SHEATHING W/ METAL STUD

INSULATION: MINERAL WOOL

CLADDING:

DATE

GREENGIRT DELTA BRACKET SIZE: 300 / 3"

ORIENTATION: VERTICAL Z-BRACKET

JAMB DETAIL

NOT TO SCALE

14F. Studs - Sill Detail



NOTE: DETAILS ARE PROVIDED FOR INFORMATION ONLY, AND ARE SUBJECT TO CHANGE WITHOUT NOTICE. SPECIFIC PROJECT ENGINEERING BY OTHERS WILL ADDRESS ATTACHMENT SPACING, ORIENTATION AND LOADING. CONTACT ADVANCED ARCHITECTURAL PRODUCTS FOR FURTHER DETAILS, AND TO INQUIRE ABOUT UPDATES AND REVISIONS. ADVANCED ARCHITECTURAL PRODUCTS IS ONLY RESPONSIBLE FOR THE THERMAL EXPANSION OF THE SUBFRAMING OF THE ADJUSTABLE SYSTEM. THE CLADDING MANUFACTURER IS RESPONSIBLE FOR HANDLING THERMAL EXPANSION OF THE CLADDING AS WELL AS THERMAL EXPANSION COMPATIBILITY WITH THE ADJUSTABLE SUBFRAMING.

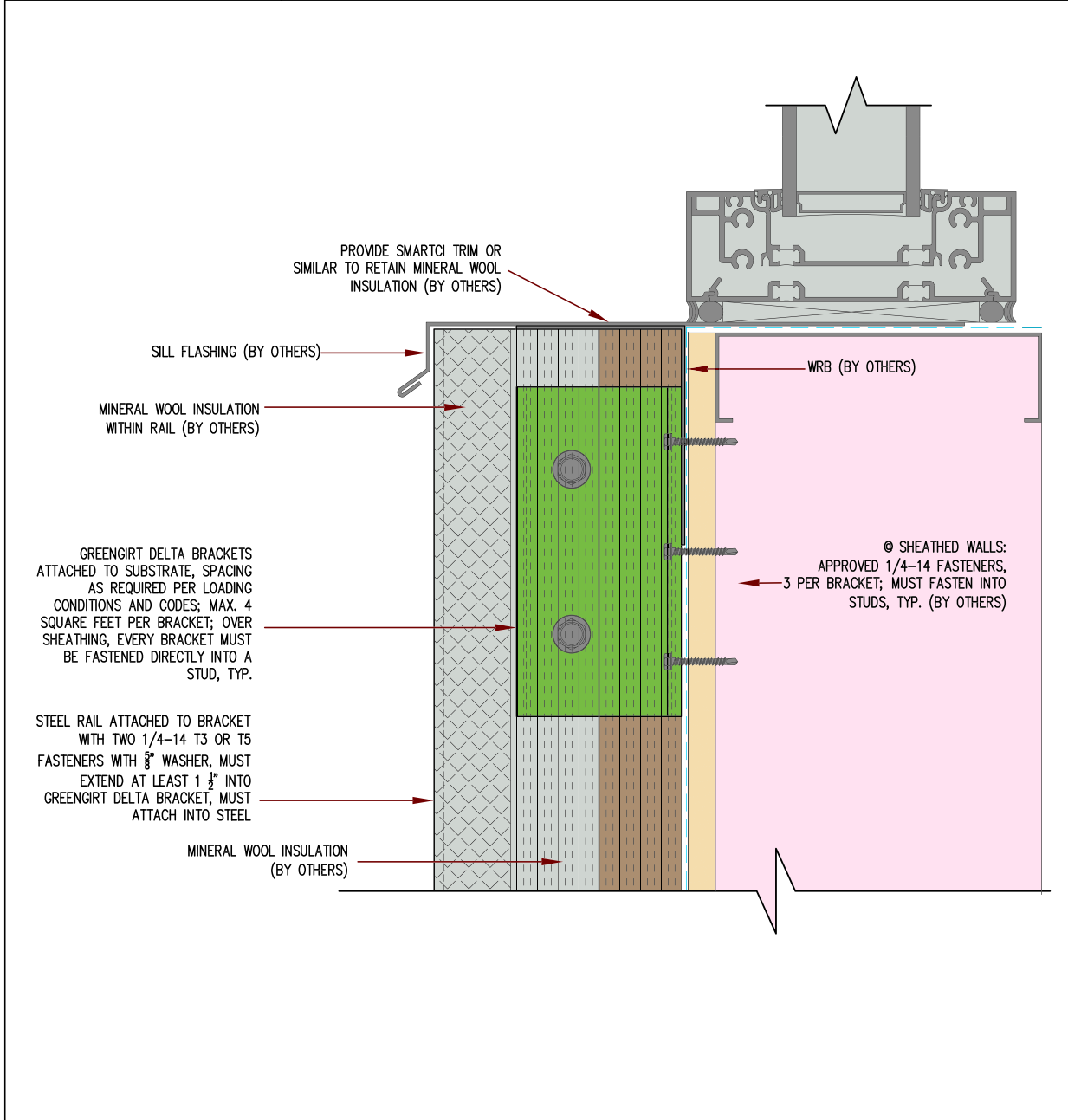

 <p>COMPOSITE METAL HYBRID ADJUSTABLE SYSTEM</p> <p>GreenGirt.com (269) 355-1818</p>	SUBSTRATE: SHEATHING W/ METAL STUD	INSULATION: MINERAL WOOL
	CLADDING:	DATE
	GREENGIRT DELTA BRACKET SIZE: 300 / 3"	ORIENTATION: VERTICAL Z-BRACKET
<h2>SILL DETAIL</h2> <p>NOT TO SCALE</p>		
7		

14G. Studs - Delta Slider with Steel L-Rail



NOTE: DETAILS ARE PROVIDED FOR INFORMATION ONLY, AND ARE SUBJECT TO CHANGE WITHOUT NOTICE. SPECIFIC PROJECT ENGINEERING BY OTHERS WILL ADDRESS ATTACHMENT SPACING, ORIENTATION AND LOADING. CONTACT ADVANCED ARCHITECTURAL PRODUCTS FOR FURTHER DETAILS, AND TO INQUIRE ABOUT UPDATES AND REVISIONS. ADVANCED ARCHITECTURAL PRODUCTS IS ONLY RESPONSIBLE FOR THE THERMAL EXPANSION OF THE SUBFRAMING OF THE ADJUSTABLE SYSTEM. THE CLADDING MANUFACTURER IS RESPONSIBLE FOR HANDLING THERMAL EXPANSION OF THE CLADDING AS WELL AS THERMAL EXPANSION COMPATIBILITY WITH THE ADJUSTABLE SUBFRAMING.

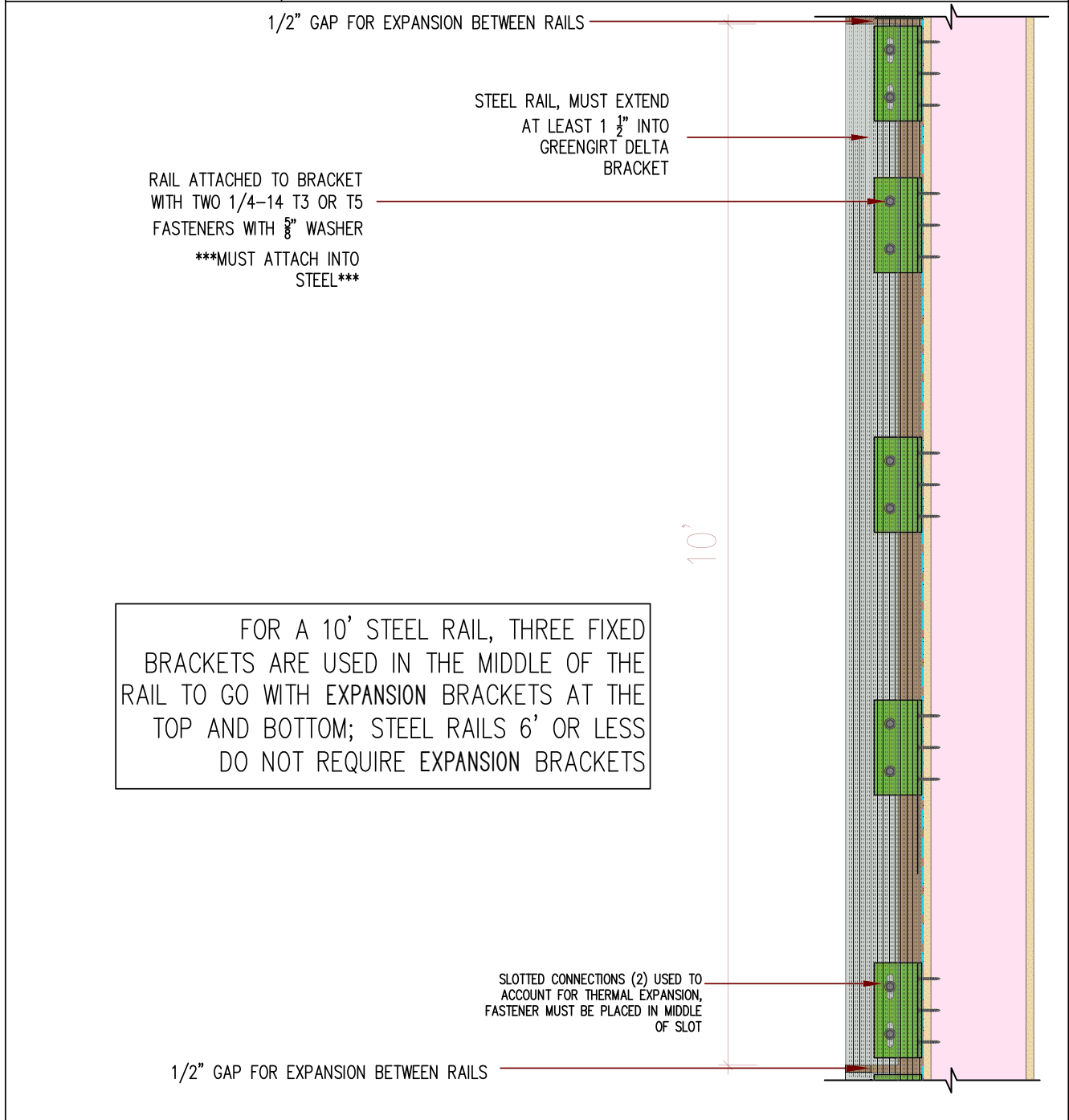

FOR A 10' STEEL RAIL, THREE FIXED BRACKETS ARE USED IN THE MIDDLE OF THE RAIL TO GO WITH EXPANSION BRACKETS AT THE TOP AND BOTTOM; STEEL RAILS 6' OR LESS DO NOT REQUIRE EXPANSION BRACKETS

<p>COMPOSITE METAL HYBRID ADJUSTABLE SYSTEM</p> <p>GreenGirt.com (269) 355-1818</p>	SUBSTRATE: SHEATHING W/ METAL STUD	INSULATION: MINERAL WOOL
	CLADDING:	DATE
	GREENGIRT DELTA BRACKET SIZE: 300 / 3"	ORIENTATION: VERTICAL Z-BRACKET
<h2>DELTA W STEEL</h2> <p>NOT TO SCALE</p>		

14H. Studs - Delta Slider with Aluminum L-Rail



NOTE: DETAILS ARE PROVIDED FOR INFORMATION ONLY, AND ARE SUBJECT TO CHANGE WITHOUT NOTICE. SPECIFIC PROJECT ENGINEERING BY OTHERS WILL ADDRESS ATTACHMENT SPACING, ORIENTATION AND LOADING. CONTACT ADVANCED ARCHITECTURAL PRODUCTS FOR FURTHER DETAILS, AND TO INQUIRE ABOUT UPDATES AND REVISIONS. ADVANCED ARCHITECTURAL PRODUCTS IS ONLY RESPONSIBLE FOR THE THERMAL EXPANSION OF THE SUBFRAMING OF THE ADJUSTABLE SYSTEM. THE CLADDING MANUFACTURER IS RESPONSIBLE FOR HANDLING THERMAL EXPANSION OF THE CLADDING AS WELL AS THERMAL EXPANSION COMPATIBILITY WITH THE ADJUSTABLE SUBFRAMING.

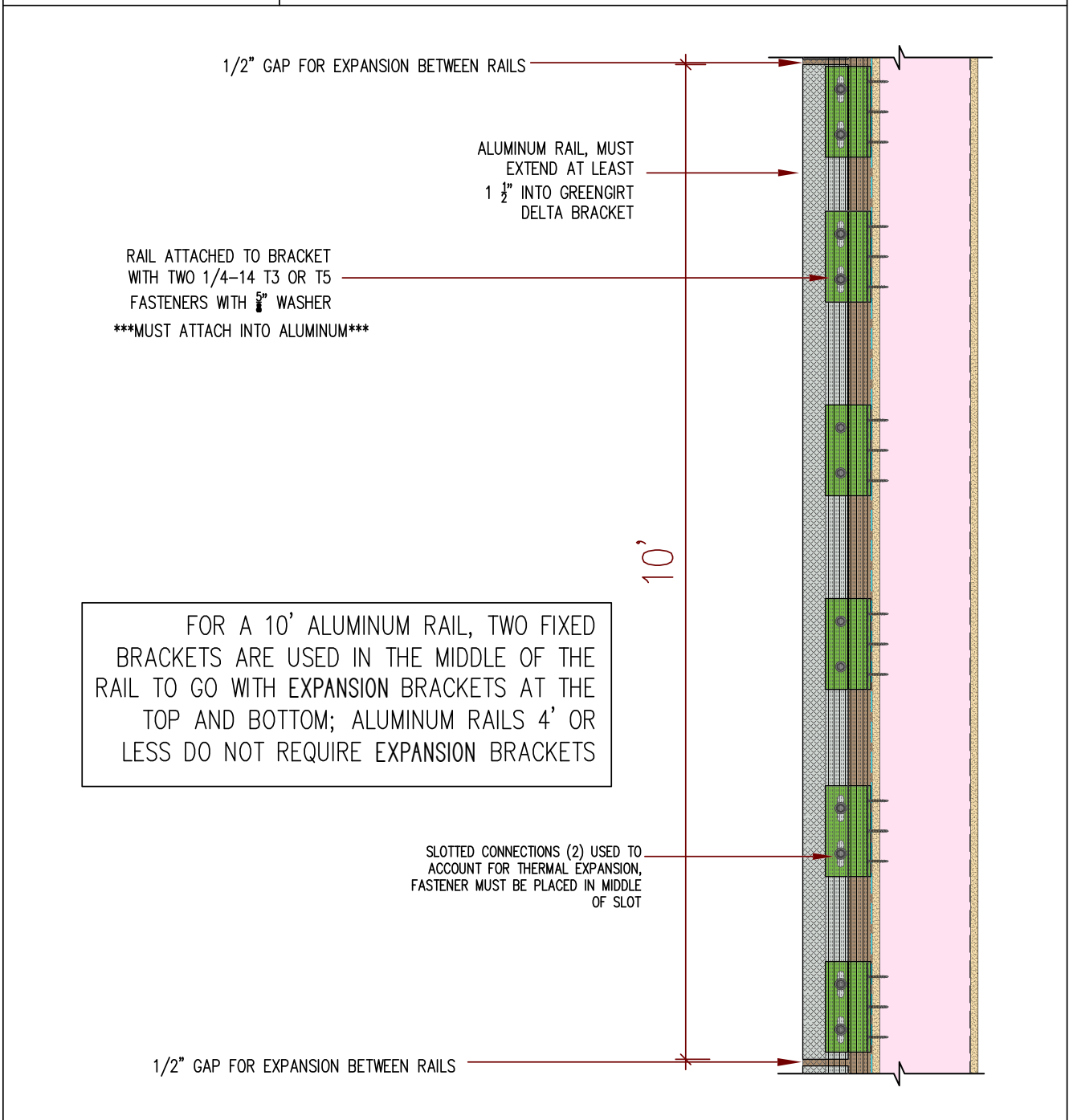

<p>COMPOSITE METAL HYBRID ADJUSTABLE SYSTEM</p> <p>GreenGirt.com (269) 355-1818</p>	SUBSTRATE: SHEATHING W/ METAL STUDS	INSULATION: MINERAL WOOL
	CLADDING:	DATE
	GREENGIRT DELTA BRACKET SIZE: 300 / 3"	ORIENTATION: VERTICAL Z-BRACKET
<h2>DELTA W ALUMINUM</h2> <p>NOT TO SCALE</p>		

14I. Studs - Delta Slider (Bottom of L-Rail)



NOTE: DETAILS ARE PROVIDED FOR INFORMATION ONLY, AND ARE SUBJECT TO CHANGE WITHOUT NOTICE. SPECIFIC PROJECT ENGINEERING BY OTHERS WILL ADDRESS ATTACHMENT SPACING, ORIENTATION AND LOADING. CONTACT ADVANCED ARCHITECTURAL PRODUCTS FOR FURTHER DETAILS, AND TO INQUIRE ABOUT UPDATES AND REVISIONS. ADVANCED ARCHITECTURAL PRODUCTS IS ONLY RESPONSIBLE FOR THE THERMAL EXPANSION OF THE SUBFRAMING OF THE ADJUSTABLE SYSTEM. THE CLADDING MANUFACTURER IS RESPONSIBLE FOR HANDLING THERMAL EXPANSION OF THE CLADDING AS WELL AS THERMAL EXPANSION COMPATIBILITY WITH THE ADJUSTABLE SUBFRAMING.

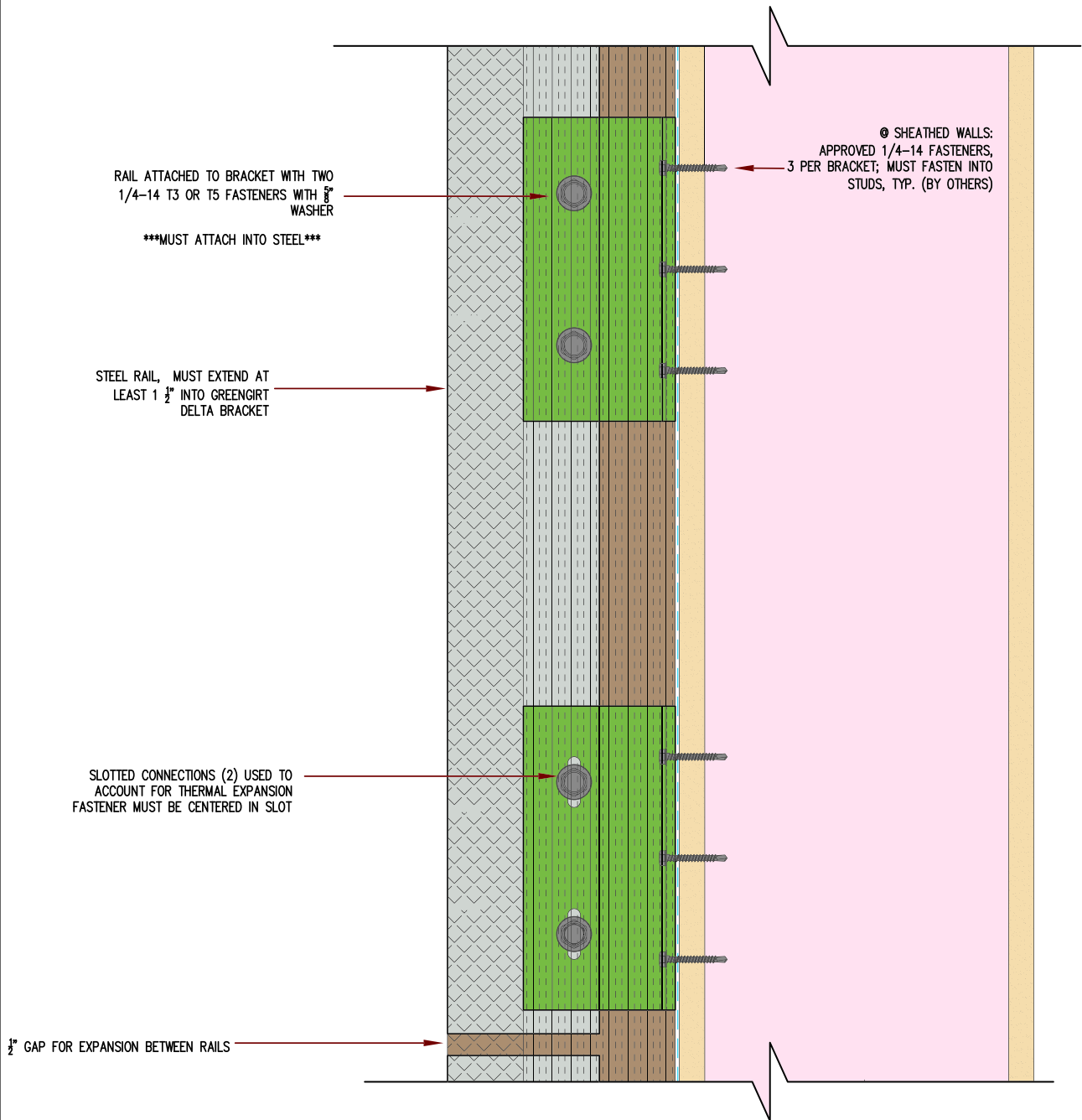

GreenGirt.com

(269) 355-1818

SUBSTRATE: SHEATHING W/ METAL STUD	INSULATION: MINERAL WOOL
CLADDING:	DATE
GREENGIRT DELTA BRACKET SIZE: 300 / 3"	ORIENTATION: VERTICAL Z-BRACKET

DELTA SLIDER (BTM OF RAIL)

NOT TO SCALE

14J. Studs - Delta Slider (Floor Joint)



NOTE: DETAILS ARE PROVIDED FOR INFORMATION ONLY, AND ARE SUBJECT TO CHANGE WITHOUT NOTICE. SPECIFIC PROJECT ENGINEERING BY OTHERS WILL ADDRESS ATTACHMENT SPACING, ORIENTATION AND LOADING. CONTACT ADVANCED ARCHITECTURAL PRODUCTS FOR FURTHER DETAILS, AND TO INQUIRE ABOUT UPDATES AND REVISIONS. ADVANCED ARCHITECTURAL PRODUCTS IS ONLY RESPONSIBLE FOR THE THERMAL EXPANSION OF THE SUBFRAMING OF THE ADJUSTABLE SYSTEM. THE CLADDING MANUFACTURER IS RESPONSIBLE FOR HANDLING THERMAL EXPANSION OF THE CLADDING AS WELL AS THERMAL EXPANSION COMPATIBILITY WITH THE ADJUSTABLE SUBFRAMING.

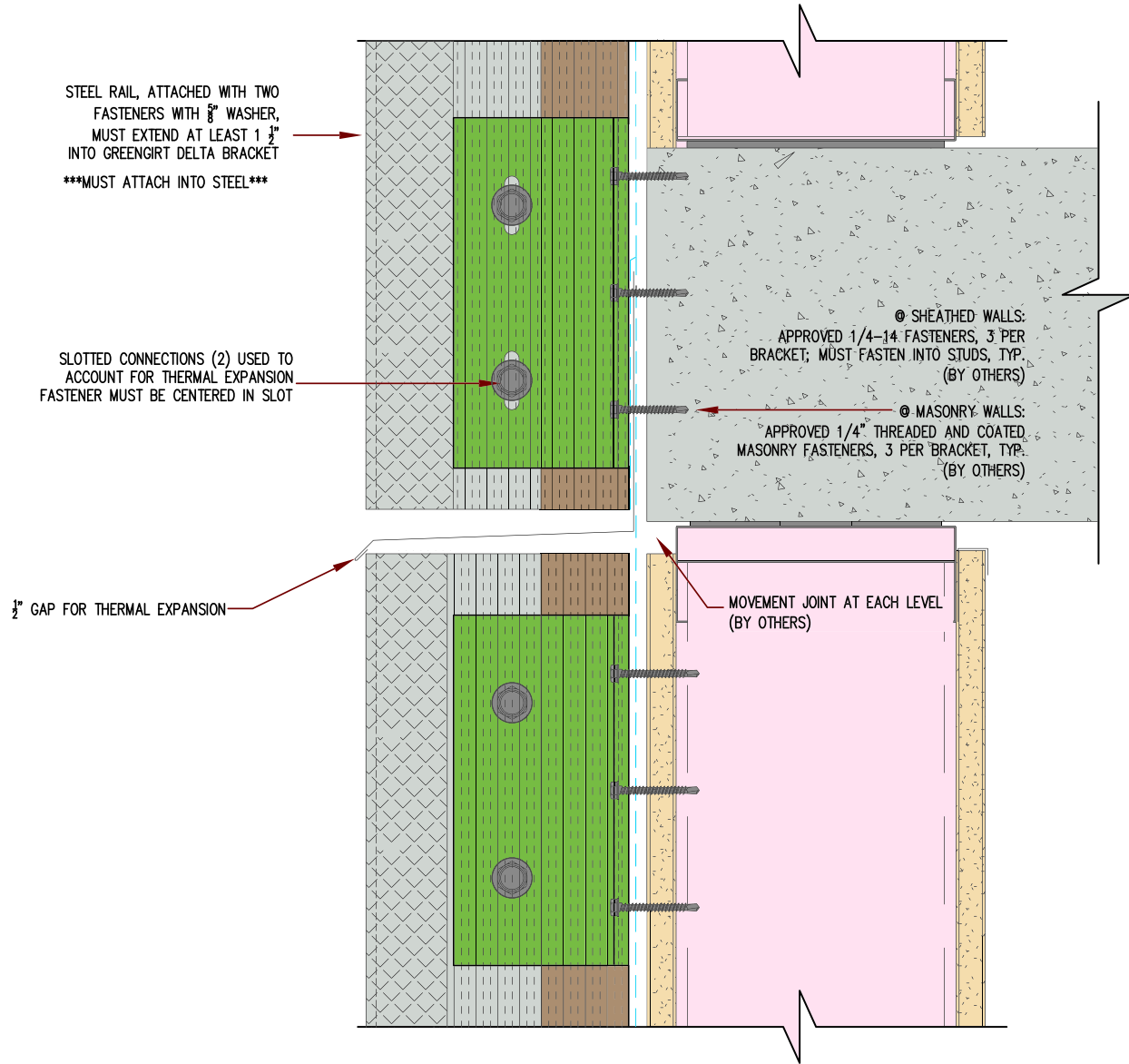

GreenGirt Delta™
COMPOSITE METAL HYBRID ADJUSTABLE SYSTEM

GreenGirt.com

(269) 355-1818

SUBSTRATE: **SHEATHING W/ METAL STUD**

INSULATION: MINERAL WOOL

CLADDING:

DATE

GREENGIRT DELTA BRACKET SIZE: 300 / 3"

ORIENTATION: VERTICAL Z-BRACKET

DELTA SLIDER (FLOOR JOINT)

NOT TO SCALE

15. Key Installation Reminders

1. Delta base bracket MUST be installed ONLY according to the shop drawings and GreenGirt Delta specifications.
2. The side-stitch fasteners should ALWAYS go through the FRP into the metal L-rail.
3. Do not cross floor/movement joints with L-rails. This will fail to account for thermal expansion of the substrate and can cause issues down the road.
4. The expansion allowance between floors should be the larger of a ½" gap or what is called out in drawings/specifications between L-rails.
5. Use expansion and fixed brackets according to the details and sample layout.
 - *Aluminum L-Rail:* A 10' section of aluminum L-rail should have two fixed brackets in the middle, with the rest expansion brackets above and below based on spacing requirements. Aluminum L-rails less than 4' long do not need any expansion brackets.
 - *Galvanized Steel L-Rail:* A 10' section of steel L-rail should have three fixed brackets in the middle, with the rest expansion above and below. Galvanized steel L-rails less than 6' long do not need any expansion brackets.
 - *CMH L-Rail:* A 10' section of CMH L-rail should have three fixed brackets in the middle, with the rest expansion above and below. CMH L-rails less than 6' long do not need any expansion brackets.

If there are any setups or situations in which the use of expansion vs. fixed brackets is a question, consult the sample layout and/or contact A2P Engineering.
6. The two required side stitch fasteners MUST be centered in the slots to account for thermal expansion. Putting them at the top or the bottom of the slot defeats its purpose.
7. Every GreenGirt Delta base bracket MUST be attached to the L-rail/clip. Note: Do not leave an L-rail non-mechanically attached.
8. Cladding accommodations for thermal expansion are up to the specific cladding manufacturers and are not the responsibility of A2P.
9. Screws utilized for installation MUST be hex heads.
10. The edge distance of any fastener-hole shall be a minimum of ½" from the edge of the profile to the closest side of the fastener-hole.
11. Impact fasteners/tools should NOT be used with the GreenGirt Delta system.
12. All GreenGirt Delta base brackets must be installed vertically with three fasteners.
13. After self-shimming on the level line, adjust L-rail to be level with the required plane.



Advanced Architectural Products

959 Industrial Drive, Allegan, MI 49010

(269) 355-1818

GreenGirt.com

© Copyright 2024 by Advanced Architectural Products. All rights reserved.

No part of this publication may be reproduced, distributed, or transmitted in any form or by any means, including photocopying, recording, or other electronic or mechanical methods, without the prior written permission of Advanced Architectural Products, except in the case of brief quotations embodied in critical reviews and certain other noncommercial uses permitted by copyright law. For permission requests, contact Advanced Architectural Products.

General revision January 2024