

GreenGirt CMH Delta™

by **Advanced Architectural Products**

GreenGirt.com

959 Industrial Drive, Allegan, MI 49010

(269) 355-1818

GreenGirt CMH Delta™ Adjustable System

Installation Guide

for Vertical Applications with Z- or L-Base Bracket and Metal L-Rail

GreenGirt CMH Delta Adjustable System



Installation Training Video

We invite you to watch the GreenGirt CMH Delta Installation Training Video available now on our website, [GreenGirt.com](https://greengirt.com). This video is designed to equip you with the knowledge and expertise required to successfully install the GreenGirt CMH Delta system.

To get started, simply scan the QR code below to begin!

**Scan
Here!**



<https://greengirt.com/products/greengirt-cmh-delta-adjustable/>

Table of Contents

| | | | |
|--|----|--|----|
| Required Tools & Accessories | 2 | 13B. Inside Corner Detail | 18 |
| Why GreenGirt CMH Delta? | 3 | 13C. Outside Corner Detail | 19 |
| Introduction | 4 | 13D. Header Detail | 20 |
| 1. System Components | 6 | 13E. Jamb Detail | 21 |
| 1A. Base Brackets | 6 | 13F. Sill Detail | 22 |
| 1B. Vertical Metal L-Rail | 8 | 13G. Delta Slider with Steel L-Rail | 23 |
| 1C. Approved Fasteners | 8 | 13H. Delta Slider with Aluminum L-Rail | 24 |
| 2. Description and Uses | 9 | 13I. Delta Slider (Bottom of Rail) | 25 |
| 3. Technical Information | 9 | 13J. Delta Slider (Floor Joint) | 26 |
| 4. Inspection Upon Delivery | 9 | 14. Construction Details on Metal Studs (Vertical) | 27 |
| 5. System Handling | 9 | 14A. Wall Section | 27 |
| 6. System Storage on Site | 10 | 14B. Inside Corner Detail | 28 |
| 7. Handling and Storage of Auxiliary Accessories | 10 | 14C. Outside Corner Detail | 29 |
| 8. Structural Alignment | 11 | 14D. Header Detail | 30 |
| 9. System Installation: GreenGirt CMH | 11 | 14E. Jamb Detail | 31 |
| 10. Installation & Surface Preparation | 11 | 14F. Sill Detail | 32 |
| 11. Installation Requirements | 15 | 14G. Delta Slider with Steel L-Rail | 33 |
| 12. Sample Elevation Layout | 16 | 14H. Delta Slider with Aluminum L-Rail | 34 |
| 13. Construction Details on Masonry (Vertical) | 17 | 14I. Delta Slider (Bottom of Rail) | 35 |
| 13A. Wall Section | 17 | 14J. Delta Slider (Floor Joint) | 36 |

Disclaimer

This installation guide is only to be used with GreenGirt CMH Delta installation drawings, and Advanced Architectural Products (A2P) suggested details. Details shown in project shop drawings take priority over similar information in this manual. Shop drawings may be created either by A2P or by the system installation contractor. A2P's Technical Service Department is available to aid the system installation contractor in the review of shop drawings. This guide is meant to furnish the system installation contractor with recommended methods, procedures, and guidelines for installing the GreenGirt CMH Delta system for commercial/industrial applications. The information presented is accurate but may not cover all circumstances, building conditions, and/or details of the specific project. Consult an A2P technical representative, as this guide does not cover every unique construction condition. It is the sole responsibility of the project engineer and system installation contractor to ensure specified air and weather tightness of a building by good design and workmanship in accordance with approved drawings, using only approved sealants/tapes. It is the sole responsibility of the owner's representative and system installation contractor to uphold quality workmanship in accordance with approved shop drawings to ensure the best operation of the system. A2P recommends installers read this document entirely before receiving materials at the job site. The guide is subject to change without notice. Installation information is available through A2P at (269) 355-1818. Follow the architect's approved shop drawings and engineering computations for project-specific fastening designs. The engineer of record is liable for verifying applicable design loads and system fastening requirements. All safety methods are the duty of the installer, general contractor, or construction manager.

IMPORTANT

Please read all information related to the project before receiving materials at the jobsite and before starting the installation.

Required Tools & Accessories



Levels



Corded / Cordless
Screw Guns



Hand Saws



Compact Corded /
Cordless Drills



Approved Fasteners



Clamps



Leather Gloves



Basic Safety
Equipment

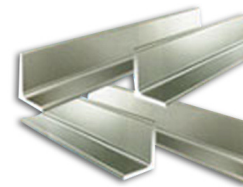

Aluminum Angles
& Strapping



Plastic Shims

IMPORTANT

Personnel working with cutting equipment and power tools should wear proper eye protection and safety equipment at all times to prevent injury.

DO NOT USE:



Reciprocating Saw



Impact Drill



Powder Actuated
Tools

CAUTION

GreenGirt CMH Delta must NOT be cut with plywood or toothed blades, as it is composed of metal, resin, and glass fibers. Use only abrasive chop saw / hand saw blades. Do not use actuated fasteners, impact hammers / impact drills or reciprocating saws!

Why GreenGirt CMH Delta™?

The Problem: Structural Misalignment

Every project has its own unique set of issues that sub-framing systems must be able to adapt to meet today's building challenges. A common problem in construction is structural misalignment and plane deviations within a building's envelope. Using a continuous insulation system that offers plane alignment while simultaneously providing energy-efficient solutions will alleviate unnecessary building challenges and costs.

The Solution: GreenGirt CMH Delta Adjustable System

GreenGirt CMH Delta was designed for the frequent changes in continuous insulation and facade design and meets the demands for energy efficiency and budget constraints. Its individual parts were created as a simple, complete solution to help make smarter buildings. The GreenGirt CMH Delta adjustable system offers a continuous insulation solution for exterior wall and plane deviations. GreenGirt CMH Delta uses structural composite metal hybrid components that provide an industry-leading, thermally efficient design while eliminating thermal bridging from metal framing and through-wall fasteners.

GreenGirt CMH Delta provides a solution for structural misalignment ranging from a small fraction of an inch to larger out of plumb issues on vertical installations. The system is available with 18 segmented options and a variety of adjustability from 0.25"– 4.5" to meet unique project needs. Easy to specify and designed as a universal cladding attachment system, GreenGirt CMH Delta can be installed on any substrate for retrofit or new construction and for any building height.

Unlike other attachment systems, GreenGirt CMH Delta prevents thermal bridging that is created by metal fasteners and framing. It doesn't create cold spots for condensation inside your walls. GreenGirt CMH Delta also has a universal attachment design for virtually any cladding.

How It Works

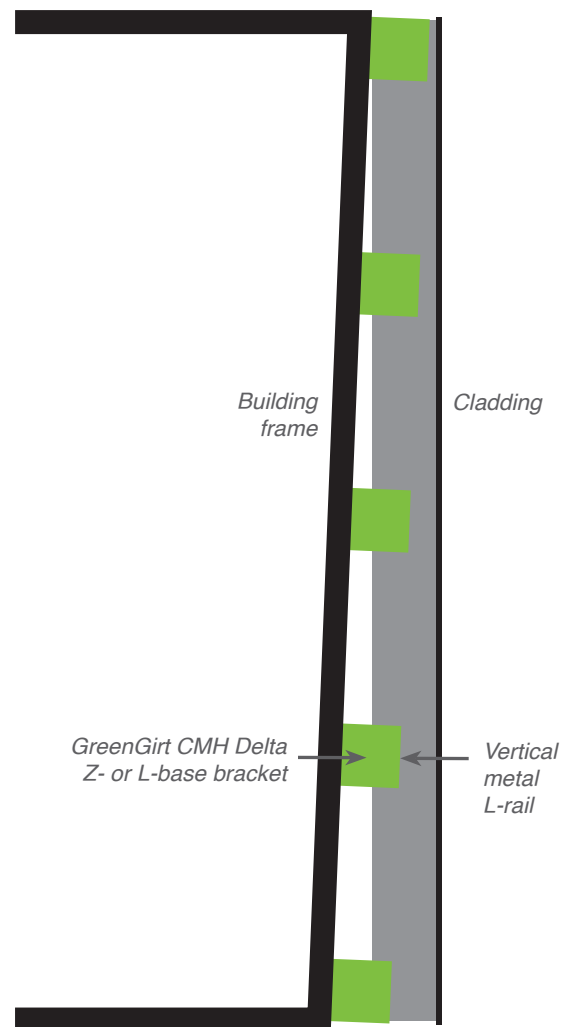

IMPORTANT

Read all information related to the project before receiving materials at the job site and before starting the installation.

Introduction

Welcome to GreenGirt CMH Delta Adjustable systems by Advanced Architectural Products. This document serves as the installation guidelines for the GreenGirt CMH Delta adjustable continuous insulation system.

GreenGirt CMH Delta provides buildings with an adjustable continuous insulation solution for exterior wall and plane deviations, and a mounting platform for the cladding application. It is an open design that works with almost any substrate, insulation, or cladding material.

GreenGirt CMH Delta provides a solution for structural misalignment ranging from a small fraction of an inch to more significant out-of-plumb issues on vertical installations. The system is also specifically designed to block off heat gaps that other systems neglect. The thermal efficiency of GreenGirt CMH Delta makes a greener, long-term building investment for the future.

The GreenGirt CMH Delta adjustable system consists of innovative insulated GreenGirt composite metal hybrid base brackets, L-rail or clips, and auxiliary accessories as needed.

1. GreenGirt CMH Delta base brackets are available in 2", 3", 4", 5", or 6" depths and should be installed vertically. Standard GreenGirt CMH Delta systems consist of 6" base bracket pieces and L-rails or clips. GreenGirt CMH Delta spacing is typically 16", 24", or 48" on center. Consult an A2P Technical Representative for loading design and capabilities for dead and live loads.
2. Insulation for the GreenGirt CMH Delta adjustable system can be specified as mineral wool.

Installation Requirements for the GreenGirt CMH Delta System:

1. Delta base bracket MUST be installed ONLY according to the shop drawings and GreenGirt CMH Delta specifications.
2. The side-stitch fasteners should ALWAYS go through the FRP into the metal L-rail.
3. Do not cross floor/movement joints with L-rails. This will fail to account for thermal expansion of the substrate and can cause issues down the road.
4. The expansion allowance between floors should be the larger of a ½" gap or what is called out in drawings/specifications between L-rails.
5. Use expansion and fixed brackets according to the details and sample layout.
 - *Aluminum L-Rail:* A 10' section of aluminum L-rail should have two fixed brackets in the middle, with the rest expansion brackets above and below based on spacing requirements. Aluminum L-rails less than 4' long do not need any expansion brackets.
 - *Galvanized Steel L-Rail:* A 10' section of steel L-rail should have three fixed brackets in the middle, with the rest expansion above and below. Galvanized steel L-rails less than 6' long do not need any expansion brackets.
 - *CMH L-Rail:* A 10' section of CMH L-rail should have three fixed brackets in the middle, with the rest expansion above and below. CMH L-rails less than 6' long do not need any expansion brackets.

If there are any setups or situations in which the use of expansion vs. fixed brackets is a question, consult the sample layout and/or contact A2P Engineering.

6. The two required side stitch fasteners MUST be centered in the slots to account for thermal expansion. Putting them at the top or the bottom of the slot defeats its purpose.
7. Every GreenGirt CMH Delta base bracket MUST be attached to the L-rail/clip. Note: Do not leave an L-rail non-mechanically attached.
8. Cladding accommodations for thermal expansion are up to the specific cladding manufacturers and are not the responsibility of A2P.
9. Screws utilized for installation MUST be hex heads.
10. The edge distance of any fastener-hole shall be a minimum of ½" from the edge of the profile to the closest side of the fastener-hole.
11. Impact fasteners/tools should NOT be used with the GreenGirt CMH Delta system.
12. All GreenGirt CMH Delta base brackets must be installed vertically with three fasteners.
13. After self-shimming on the level line, adjust L-rail to be level with the required plane.

1. System Components

GreenGirt CMH Delta Base Bracket with Dual Grip Technology

GreenGirt CMH Delta adjustable system consists of innovative GreenGirt CMH Delta base brackets, a primary insulator, and auxiliary accessories, as needed. The GreenGirt CMH Delta system is available with 18 segmented options with a wide range of adjustability from 0.25"–4.5" variation to meet the unique needs of each project requiring a vertical application.

1A. GreenGirt CMH Delta Base Bracket

Z-Base Bracket vs. L-Base Bracket

GreenGirt CMH Delta base brackets are available in two shapes: Z-profile and L-profile. The Z-profile includes a front flange helping with insulation retention. The L-profile base bracket does not include the front flange, which offers versatility and compatibility with insulation depths. In addition, both the Z- and L-profiles offer the same adjustability range.

Z-Base Bracket

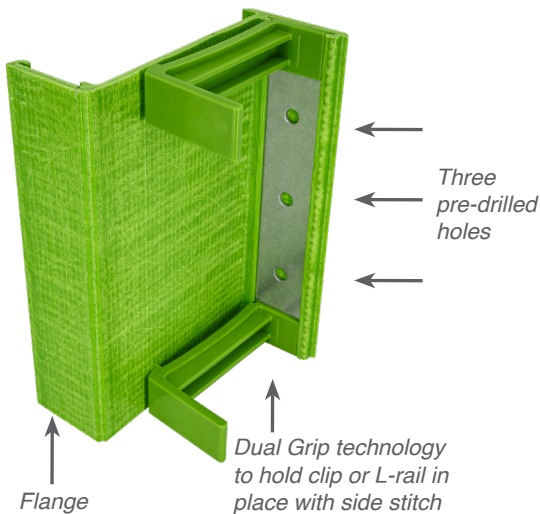

L-Base Bracket

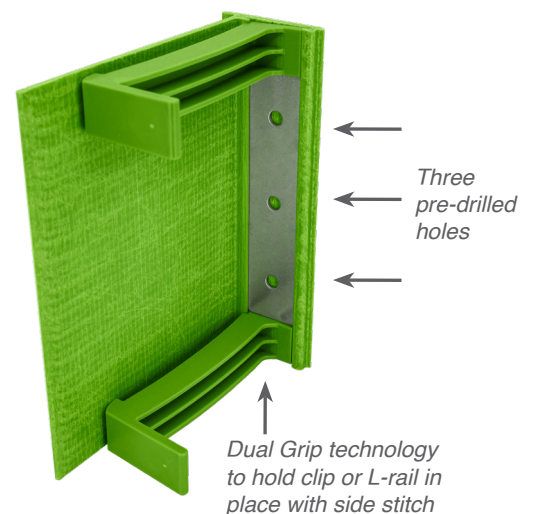

**GreenGirt CMH Delta Adjustable System
Z-Base Bracket (with flange)**

| Product # | Depth (in) | Range of Adjustment | |
|-----------|------------|---------------------|-------|
| | | Min. | Max. |
| 3DZ2RGCE | 3" | 3.25" | 7.5" |
| 4DZ3RGCE | 4" | 4.25" | 8.5" |
| 5DZ4RGCE | 5" | 5.25" | 9.5" |
| 6DZ5RGCE | 6" | 6.25" | 10.5" |

**GreenGirt CMH Delta Adjustable System
L-Base Bracket (no flange)**

| Product # | Depth (in) | Range of Adjustment | |
|-----------|------------|---------------------|-------|
| | | Min. | Max. |
| 3DL2RGCE | 3" | 3.25" | 7.5" |
| 4DL3RGCE | 4" | 4.25" | 8.5" |
| 5DL4RGCE | 5" | 5.25" | 9.5" |
| 6DL5RGCE | 6" | 6.25" | 10.5" |

Fixed vs. Expansion GreenGirt CMH Delta Base Brackets

With the wide variances in temperature within a building envelope, thermal expansion must be accounted for. For example, a 10' aluminum rail will expand by almost 3/16" with a 100-degree F change in temperature, and with that expansion comes stress on whatever the L-rail is attached to.

When a vertical continuous L-rail is used, two types of GreenGirt CMH Delta base brackets will be used: fixed and expansion. The expansion base brackets will come pre-punched with two slots, while the fixed brackets will not be punched.

Putting expansion GreenGirt CMH Delta base brackets at the top and bottom of the L-rail helps to accommodate thermal movement. The L-rails also will have a gap in between adjacent rails in order to leave room for thermal expansion. Two fasteners will still be used for every fixed and expansion base bracket and must be fastened into the L-rail.

The number of expansion brackets will vary based on spacing and material.

- *Aluminum L-Rail:* A 10' section of aluminum L-rail should have two fixed brackets in the middle, with the rest expansion brackets above and below based on spacing requirements. Aluminum L-rails less than 4' long do not need any expansion brackets.
- *Galvanized Steel L-Rail:* A 10' section of steel L-rail should have three fixed brackets in the middle, with the rest expansion brackets above and below. Galvanized steel L-rails less than 6' long do not need any expansion brackets.
- *CMH L-Rail:* A 10' section of CMH L-rail should have three fixed brackets in the middle, with the rest expansion brackets above and below. CMH L-rails less than 6' long do not need any expansion brackets.

Expansion Base Bracket

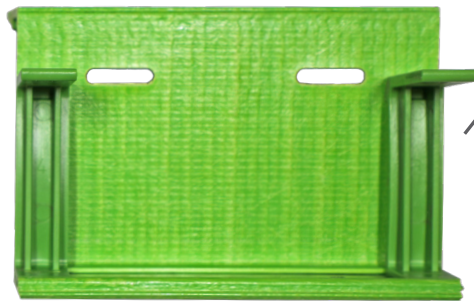

Fixed Base Bracket

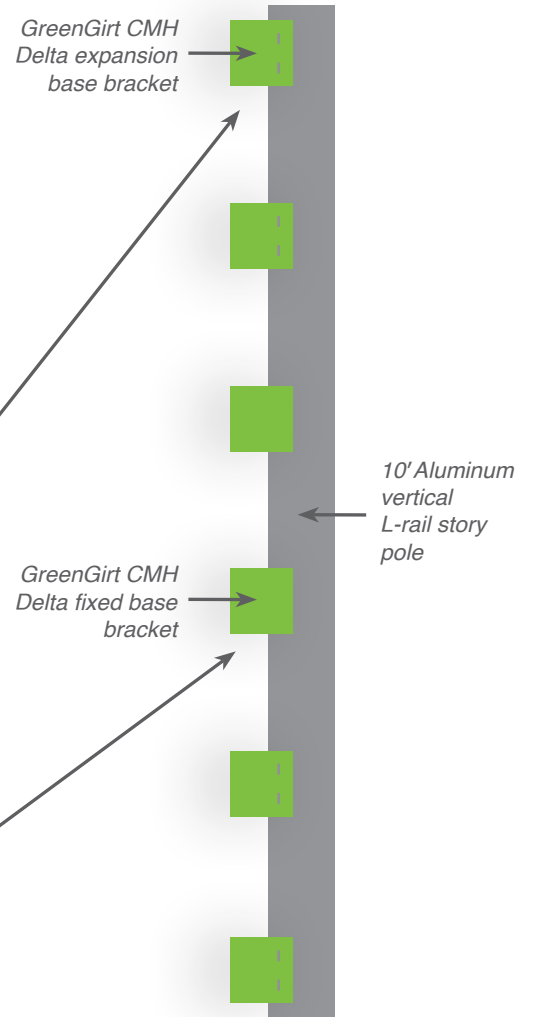

***Reference engineered shop drawings for fixed vs. expansion bracket locations and placement.**

1B. Vertical Metal L-Rail



| Vertical Metal L-Rail | | | | | | |
|-----------------------|-----------|--------|-----------|-----------|-----------|-----------|
| Material | Product # | Length | Dim. | Dim. | Dim. | Dim. |
| Galvanized Steel | MGAL VR10 | 10' | 1.5" x 3" | 1.5" x 4" | 1.5" x 5" | 1.5" x 6" |
| Aluminum | MALU VR10 | 10' | 1.5" x 3" | 1.5" x 4" | 1.5" x 5" | 1.5" x 6" |

1C. Approved Fasteners

Fasteners for Z-Base Bracket Attachment to Studs



Washed Head
1/4"-14 Fastener (T3)

Fasteners for Z-Base Bracket Attachment to Masonry Walls



1/4" Threaded and Coated
Masonry Fastener

Fasteners for side stitching from Z-base bracket to steel/aluminum/CMH L-rail



Washed Head
1/4"-14 Fasteners (T3)



Washed Head
1/4"-14 Fasteners (T5)

IMPORTANT

Ensure correct fasteners are used. Side stitch fasteners
MUST go from CMH into metal.

2. Description and Uses

The GreenGirt CMH Delta system is an innovative, complete adjustable continuous insulation solution. Engineered as an adjustable continuous insulation system, the GreenGirt CMH Delta system includes composite metal hybrid base brackets, L-rail or clips, an engineered installation package, and optional accessories.

GreenGirt CMH Delta joins the building cladding and insulation to a structure. It's an insulated composite metal hybrid sub-framing component that can be installed vertically.

3. Technical Information

Performance & Quality

Please note failure to follow the precise procedures outlined in this Installation Guide, all applicable laws, ordinances, and codes, and/or accepted industry safety procedures will render any and all warranties null and void. A2P will not be responsible in any way for merchandise, installed or not, that is damaged or defective as a result of negligible practices and/or a failure to follow these guidelines, deficiencies in workmanship or construction, or dangerous site conditions.

Warranties and other product information are available from A2P. For information regarding general and product-specific warranties, please contact A2P at (269) 355-1818.

4. Inspection Upon Delivery

GreenGirt CMH Delta is professionally packaged, wrapped, and carefully shipped on flatbed trailers to the construction site. When a shipment is received, check all items against the shipping document for quantities, dimensions, colors, transit damage, etc. Document any shortage of girts and accessories or any damage on the bill of lading and have it signed by the driver. It is the receiver's responsibility to make any damage claims immediately. Please note that although every effort is made to prevent shipping damage, A2P is not responsible for damage that may occur during transportation, delivery, storage, or on-site handling.

5. System Handling

5.1 Pallets Handled by Forklift

Inspect travel route to assure a reasonable level and compacted surface free of ruts and excavations.

Prior to moving any pallet, ensure all boxes are secured. The recommended loading/unloading method for boxes is to use a single forklift with appropriately-spaced forks placed under the center of the pallet, transporting only one at a time.

Note: Do not stack pallets on top of boxes.

5.2 Pallets Handled by Crane

Carefully pick up boxes one at a time to prevent damage while lifting.

Prior to lifting any pallet, ensure all boxes are secured. The recommended crane lifting method is to use nylon straps positioned at a minimum of two points along the length of the pallet. Suitable wood spreaders should be used and located at the top and bottom of the pallets at the strap positions to protect the edges.

Extreme care should be taken to avoid bumping pallets when lifting.

6. System Storage on Site

The site must have adequate storage space to receive and store GreenGirt CMH Delta components. This space must be level, firm, clean, and free from standing water. Components should be stored in a dry condition, off the ground, and covered continuously when not in use. Avoid outdoor storing for longer than 45 days.

If GreenGirt CMH Delta components are to be used immediately, pallets/boxes should be placed at preplanned strategic locations around the building perimeter, as close as possible to the specific work areas. Review installation shop drawings to determine the best locations.

When handling GreenGirt CMH Delta components, ropes, steel cables, or chains must not be used.

IMPORTANT

GreenGirt CMH Delta packages are non-load bearing! Do NOT stack other objects on top of the bundles, such as bricks, metal, lumber, and other materials.

7. Handling and Storage of Auxiliary Accessories

Care should be taken during unloading and storage to prevent damage to items, such as GreenGirt CMH Delta base brackets, clips, or L-rails.

Cover all pallet crates or boxes to protect materials from the weather but allow for ventilation to prevent condensation. Temperature-sensitive items such as butyl tapes and sealants should be stored under controlled conditions to maintain suitable application characteristics.

8. Structural Alignment

Review shop drawings before installation to verify that structural members are in the correct location.

Installer must examine the alignment of the substrate before installation of the GreenGirt CMH Delta system. The substrate must be examined for plane deviations or structural misalignment, and support members to which panels are attached must be in the same plane, flat and free of obstructions such as weld marks, bolts or screw heads.

Support members shall be installed within the following tolerances of plus or minus 1/8" (3.17 mm) in 10' (3048 mm) in any direction along the plane of framing, with non-accumulative spaces.

Any variance from tolerances can affect performance and aesthetics and must be reported to the architect and general contractor and corrected by the responsible party before installation begins.

9. System Installation: GreenGirt CMH Delta

When attaching fasteners to GreenGirt CMH Delta, the following general guidelines are to be observed:

1. The edge distance of any fastener-hole shall be a minimum of 1/2" from the edge of the profile to the closest side of the fastener-hole.
2. The minimum clear distance between holes is 5x diameter.
3. The minimum edge (edge of profile to edge of hole) distance in the longitudinal direction is 3x diameter.
4. The minimum edge (edge of profile to edge of hole) distance in the transversal direction is 2x the diameter.

10. Installation & Surface Preparation

Before installing GreenGirt CMH Delta, ensure that the substrate is dry, clean, sound, and free of any debris, residue, and any other surface contaminants.

Orientation: GreenGirt CMH Delta Z- or L-base brackets can only be installed vertically.

Alignment: GreenGirt CMH Delta Z- or L-base brackets must be aligned vertically to place metal clips and hat channels.

10.1 Installer Selection

A2P recommends that the GreenGirt CMH Delta system is only installed under the direct supervision of an experienced craftsman trained in properly applying its diverse offering of products and services. Please call (269) 355-1818 for information regarding authorized installer selection and training programs.

IMPORTANT

Ensure brackets are aligned vertically to each other on substrate.
A2P should be contacted for all projects to verify allowable spacing.

10.2 Masonry & Concrete

Remove high spots and fill in low spots before attaching GreenGirt CMH Delta to concrete or masonry substrate. Remove any extra materials protruding on the surface of walls, such as chunks of mortar or concrete, and even wall surface to within 1/4" per 8'.

GreenGirt CMH Delta Z- or L-base brackets must be flat against the substrate and perpendicular to the plane of the substrate. Fasten GreenGirt CMH Delta Z- or L-base brackets vertically to the masonry substrate with approved threaded and coated 1/4" masonry fasteners of sufficient loading capacity for the application utilizing **all three pre-drilled holes** in the steel insert. Fastening is predicated by project specifications and requirements.

10.3 Steel & Wood Stud

Verify the substrate is flat, without steps or voids greater than 1/4" over a 20' span. GreenGirt CMH Delta Z- or L-base brackets must be flat against the substrate and perpendicular to the plane of the substrate. Attach GreenGirt CMH Delta Z- or L-base brackets vertically to framing with approved 1/4" x 14 fasteners of sufficient loading capacity for the application, using **all three pre-drilled holes** in the steel insert. Fastening is predicated by project specifications and requirements.

CAUTION

Impact fasteners or impact power tools should not be used to install GreenGirt CMH Delta Z- or L-base brackets with any substrate.

(Applies to both Z- or L-base bracket)

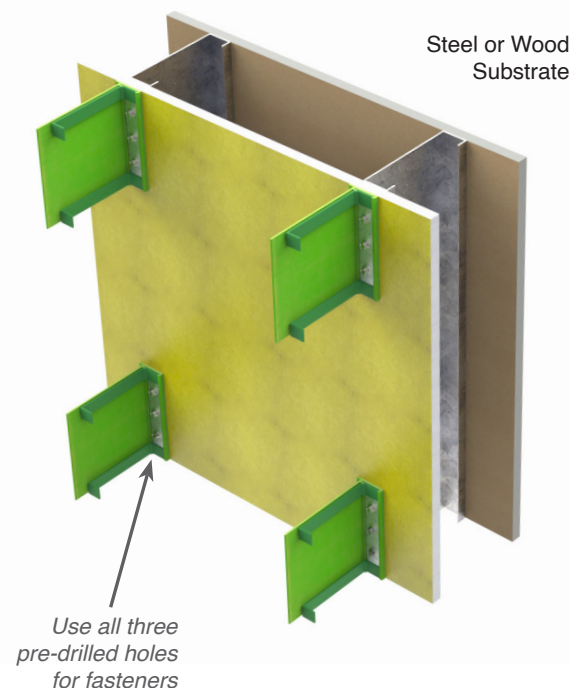
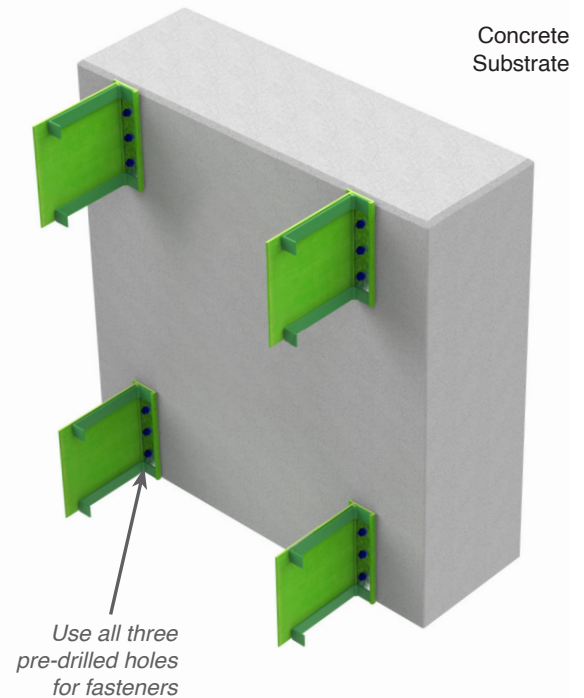

10.4 Metal L-Rail Fastening

The metal L-rail may be made of aluminum or steel. Secondary material or scrap should not be used for either type of rail.

Vertical Clip Install

Fiber-reinforced polymer (FRP) material should never be the final material fastened into when attaching to a metal L-rail from the GreenGirt CMH Delta Z- or L-base bracket. If an aluminum or steel L-rail is used, the attachment should be fastened through the FRP into the aluminum or steel rail. Two staggered fasteners with 5/8" washers should be used to attach the metal L-rail to every GreenGirt CMH Delta Z- or L-base bracket, with the fasteners being spaced apart by at least five times the diameter of the fastener.

The metal L-rail used with the GreenGirt CMH Delta Z- or L-base bracket should be attached so that at least 1½" of the depth of the clip is attached to the Z- or L-base bracket. If a deeper metal L-rail is needed, a deeper Z- or L-base bracket should be used.

Special attention is required at terminations and floor lines.

Z-Base Bracket with Metal L-Rail

(with flange)

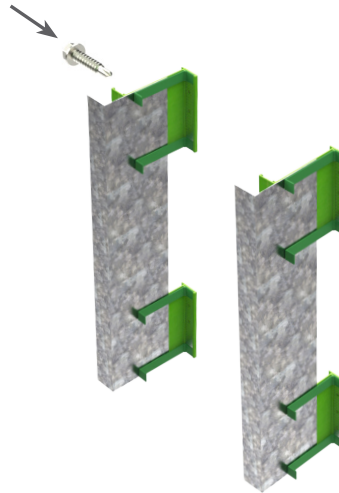

L-Base Bracket with Metal L-Rail

(without flange)

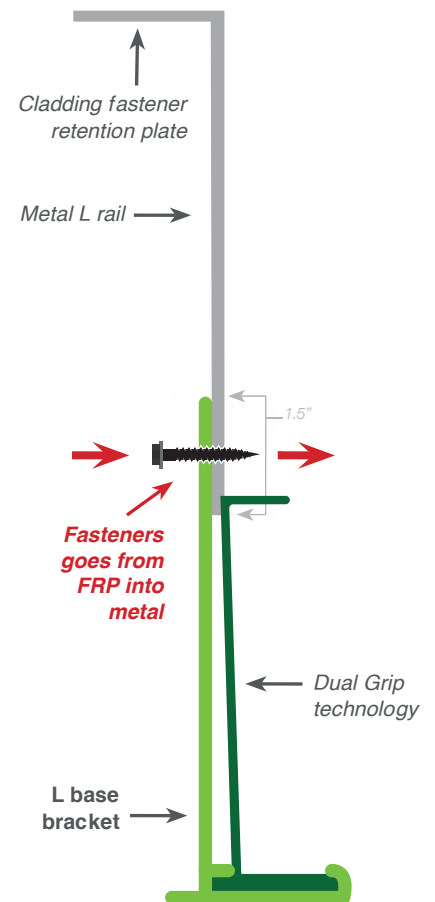
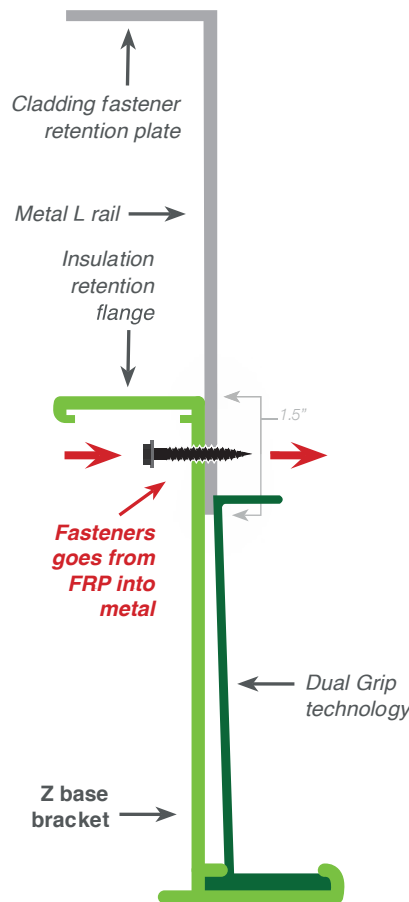
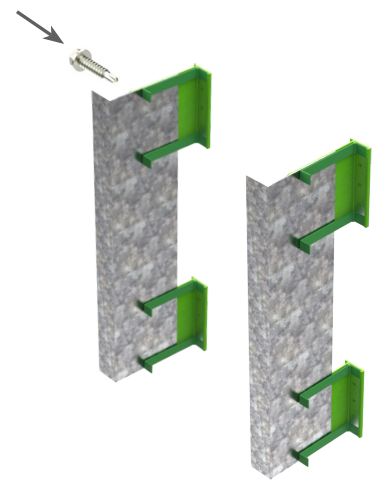

IMPORTANT

Ensure correct fasteners are used.
Side stitch fasteners MUST go from FRP into metal.

10.5 Insulation

Mineral wool must be used with the GreenGirt CMH Delta System. Certain cladding types have a maximum air gap when tested for NFPA 285 compliance, and using the adjustable CMH system does not exempt one from that requirement. For best practices, mineral wool should fill from the back of the GreenGirt CMH Delta Z-base brackets to the front of the rail. If the cladding assembly allows, mineral wool can be used with just the GreenGirt CMH Delta Z-base brackets and placed within the rails around openings to avoid a “chimney effect” for fire.

Insert mineral wool insulation left to right, utilizing the Dual Grip retention technology to puncture the insulation on the left side and tuck the insulation behind the GreenGirt CMH Delta base bracket flange on the right side.

Note: All insulation requirements are predicated by the project specifications and requirements.

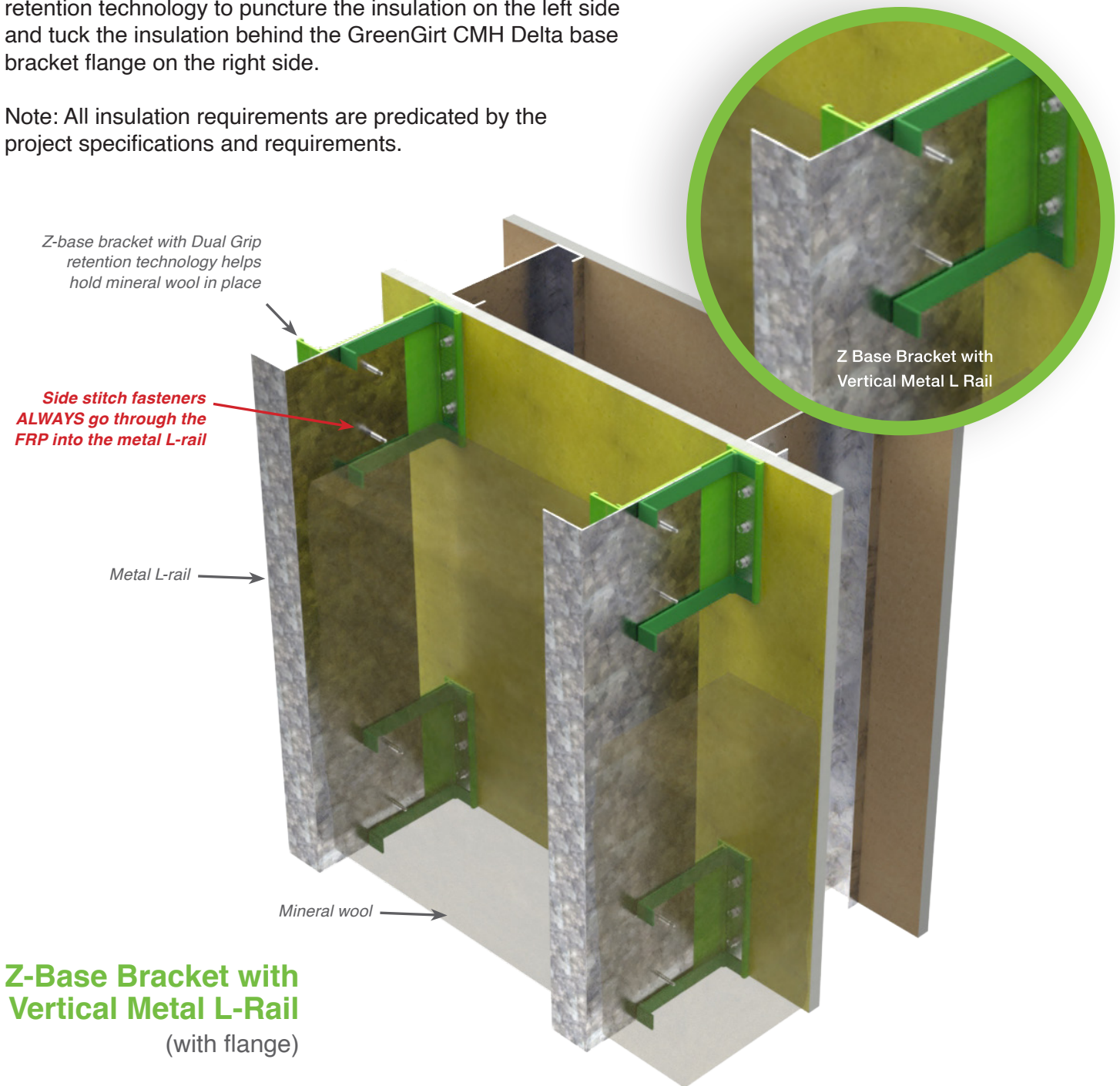

A2P is only responsible for the thermal expansion of the sub-framing of the GreenGirt CMH Delta system. The cladding manufacturer is responsible for handling the thermal expansion of the cladding, as well as compatibility with the GreenGirt CMH Delta system.

11. Installation Requirements

The following pages include a sample elevation layout and sample details that state what to do at floor joints, L-rail terminations, etc.

The sample layout shows where the rows of fixed vs. expansion GreenGirt CMH Delta base brackets go on a typical elevation. It also indicates that a bracket is needed at the top and bottom of the L-rails and that the L-rail cannot cross floor/movement joints. Those respective details are found in the pages following the sample layout.

1. Delta base bracket **MUST** be installed **ONLY** according to the shop drawings and GreenGirt CMH Delta specifications.
2. The side-stitch fasteners should **ALWAYS** go through the FRP into the metal L-rail.
3. Do not cross floor/movement joints with L-rails. This will fail to account for thermal expansion of the substrate and can cause issues down the road.
4. The expansion allowance between floors should be the larger of a ½" gap or what is called out in drawings/specifications between L-rails.
5. Use expansion and fixed brackets according to the details and sample layout.
 - *Aluminum L-Rail:* A 10' section of aluminum L-rail should have two fixed brackets in the middle, with the rest expansion brackets above and below based on spacing requirements. Aluminum L-rails less than 4' long do not need any expansion brackets.
 - *Galvanized Steel L-Rail:* A 10' section of steel L-rail should have three fixed brackets in the middle, with the rest expansion brackets above and below. Galvanized steel L-rails less than 6' long do not need any expansion brackets.
 - *CMH L-Rail:* A 10' section of CMH L-rail should have three fixed brackets in the middle, with the rest expansion brackets above and below. CMH L-rails less than 6' long do not need any expansion brackets.

If there are any setups or situations in which the use of expansion vs. fixed brackets is a question, consult the sample layout and/or contact A2P Engineering.

6. The two required side stitch fasteners **MUST** be centered in the slots to account for thermal expansion. Putting them at the top or the bottom of the slot defeats its purpose.
7. Every GreenGirt CMH Delta base bracket **MUST** be attached to the L-rail/clip. Note: Do not leave an L-rail non-mechanically attached.
8. Cladding accommodations for thermal expansion are up to the specific cladding manufacturers and are not the responsibility of A2P.
9. Screws utilized for installation **MUST** be hex heads.
10. The edge distance of any fastener-hole shall be a minimum of ½" from the edge of the profile to the closest side of the fastener-hole.
11. Impact fasteners/tools should **NOT** be used with the GreenGirt CMH Delta system.
12. All GreenGirt CMH Delta base brackets must be installed vertically with three fasteners.
13. After self-shimming on the level line, adjust L-rail to be level with the required plane.

12. Sample Elevation Layout

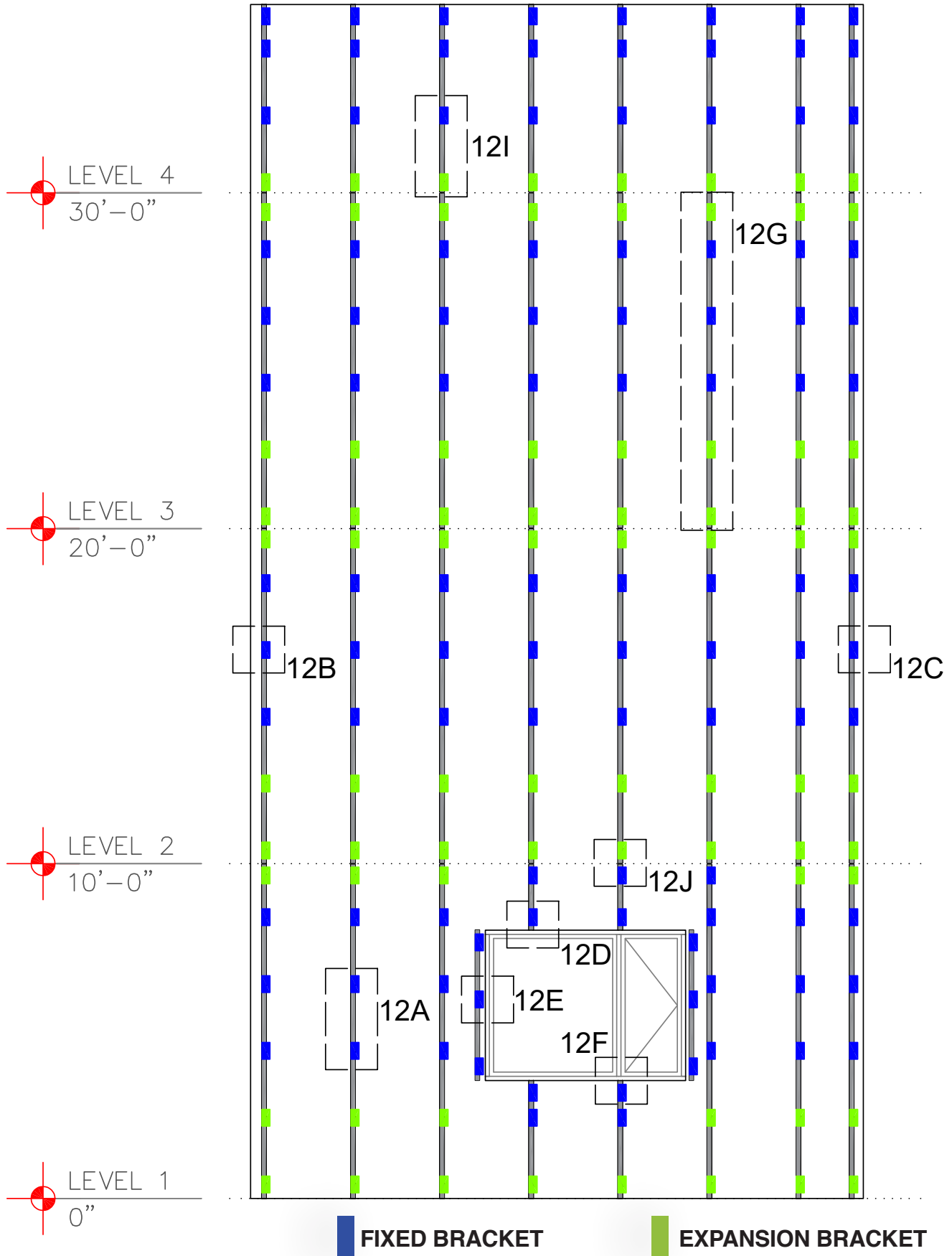

13A. Construction Details on Masonry (Vertical) - Wall Section



NOTE: DETAILS ARE PROVIDED FOR INFORMATION ONLY, AND ARE SUBJECT TO CHANGE WITHOUT NOTICE. SPECIFIC PROJECT ENGINEERING BY OTHERS WILL ADDRESS ATTACHMENT SPACING, ORIENTATION AND LOADING. CONTACT ADVANCED ARCHITECTURAL PRODUCTS FOR FURTHER DETAILS, AND TO INQUIRE ABOUT UPDATES AND REVISIONS ADVANCED ARCHITECTURAL PRODUCTS IS ONLY RESPONSIBLE FOR THE THERMAL EXPANSION OF THE SUBFRAMING OF THE ADJUSTABLE SYSTEM. THE CLADDING MANUFACTURER IS RESPONSIBLE FOR HANDLING THERMAL EXPANSION OF THE CLADDING AS WELL AS THERMAL EXPANSION COMPATIBILITY WITH THE ADJUSTABLE SUBFRAMING.

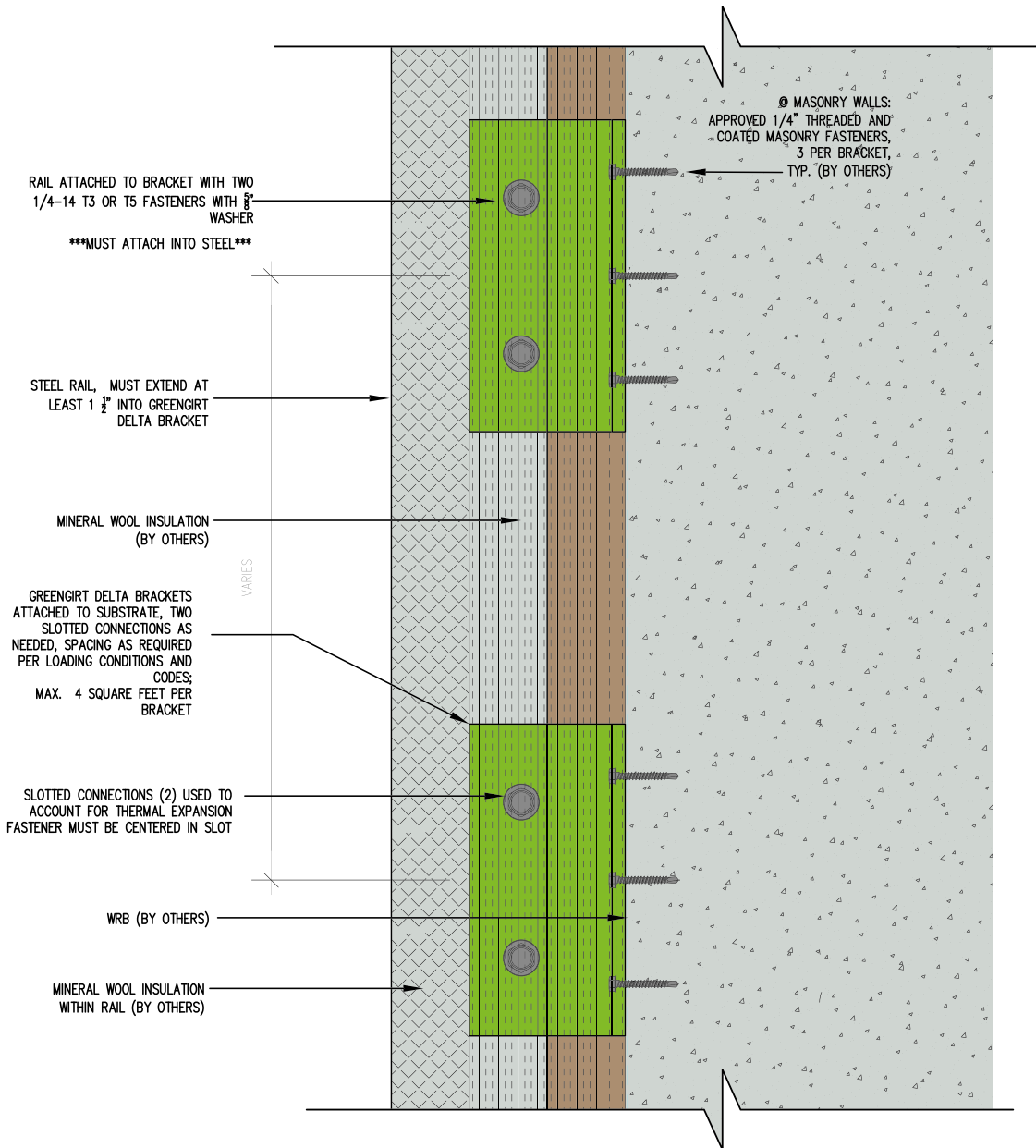

GreenGirt CMH Delta™

GreenGirt.com

(269) 355-1818

SUBSTRATE: **MASONRY**

CLADDING:

GREENGIRT DELTA BRACKET SIZE: 3"

3" STEEL RAIL WITH 3" DELTA

NOT TO SCALE

INSULATION: MINERAL WOOL

DATE

ORIENTATION: VERTICAL L-BRACKET

13B. Masonry - Inside Corner Detail



NOTE: DETAILS ARE PROVIDED FOR INFORMATION ONLY, AND ARE SUBJECT TO CHANGE WITHOUT NOTICE. SPECIFIC PROJECT ENGINEERING BY OTHERS WILL ADDRESS ATTACHMENT SPACING, ORIENTATION AND LOADING. CONTACT ADVANCED ARCHITECTURAL PRODUCTS FOR FURTHER DETAILS, AND TO INQUIRE ABOUT UPDATES AND REVISIONS. ADVANCED ARCHITECTURAL PRODUCTS IS ONLY RESPONSIBLE FOR THE THERMAL EXPANSION OF THE SUBFRAMING OF THE ADJUSTABLE SYSTEM. THE CLADDING MANUFACTURER IS RESPONSIBLE FOR HANDLING THERMAL EXPANSION OF THE CLADDING AS WELL AS THERMAL EXPANSION COMPATIBILITY WITH THE ADJUSTABLE SUBFRAMING.

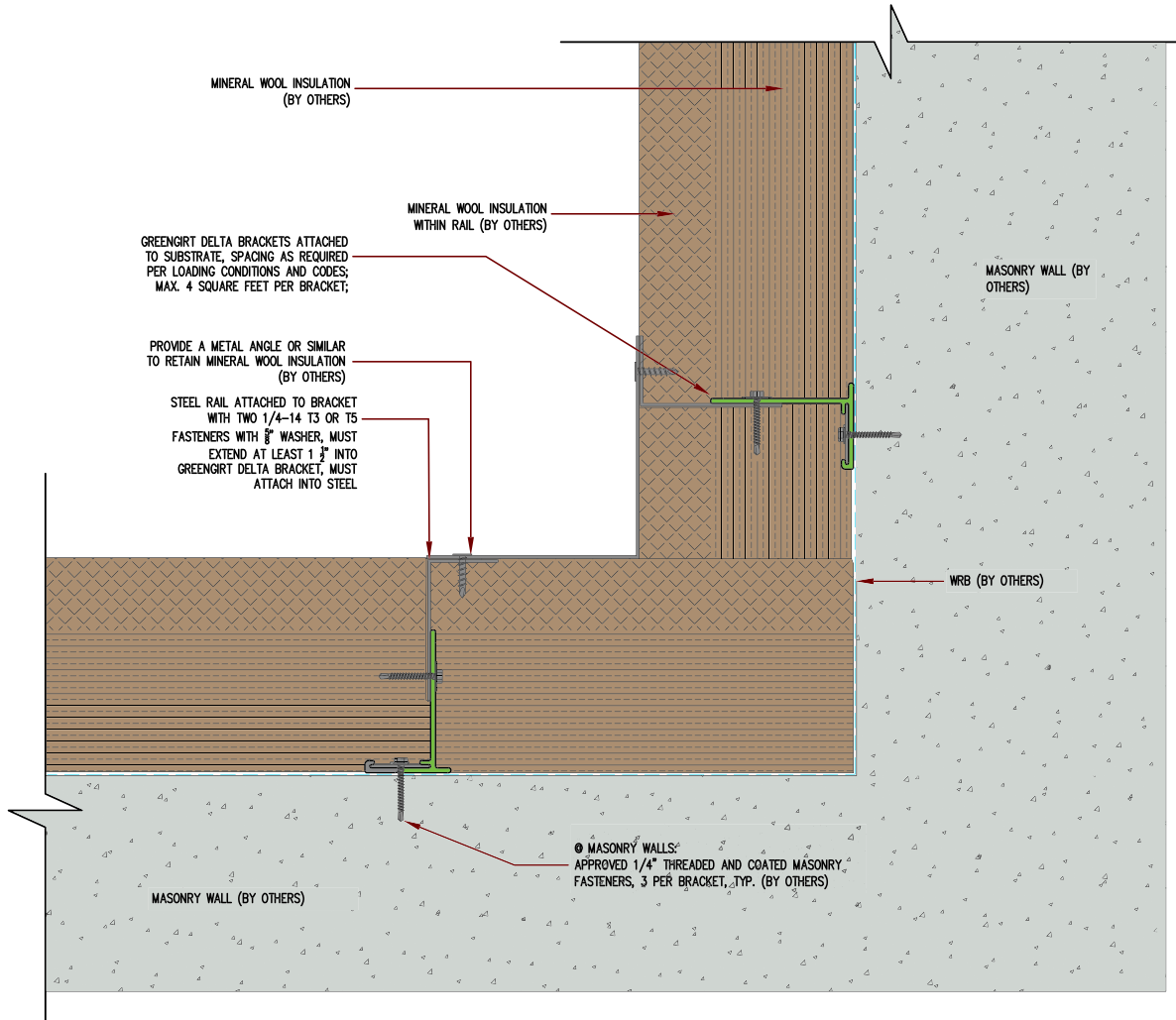

GreenGirt Delta™
COMPOSITE METAL HYBRID ADJUSTABLE SYSTEM

GreenGirt.com

(269) 355-1818

| | |
|--|---------------------------------|
| SUBSTRATE: MASONRY | INSULATION: MINERAL WOOL |
| CLADDING: | DATE |
| GREENGIRT DELTA BRACKET SIZE: 300 / 3" | ORIENTATION: VERTICAL Z-BRACKET |

INSIDE CORNER DETAIL

NOT TO SCALE

4

13C. Masonry - Outside Corner Detail



NOTE: DETAILS ARE PROVIDED FOR INFORMATION ONLY, AND ARE SUBJECT TO CHANGE WITHOUT NOTICE. SPECIFIC PROJECT ENGINEERING BY OTHERS WILL ADDRESS ATTACHMENT SPACING, ORIENTATION AND LOADING. CONTACT ADVANCED ARCHITECTURAL PRODUCTS FOR FURTHER DETAILS, AND TO INQUIRE ABOUT UPDATES AND REVISIONS. ADVANCED ARCHITECTURAL PRODUCTS IS ONLY RESPONSIBLE FOR THE THERMAL EXPANSION OF THE SUBFRAMING OF THE ADJUSTABLE SYSTEM. THE CLADDING MANUFACTURER IS RESPONSIBLE FOR HANDLING THERMAL EXPANSION OF THE CLADDING AS WELL AS THERMAL EXPANSION COMPATIBILITY WITH THE ADJUSTABLE SUBFRAMING.

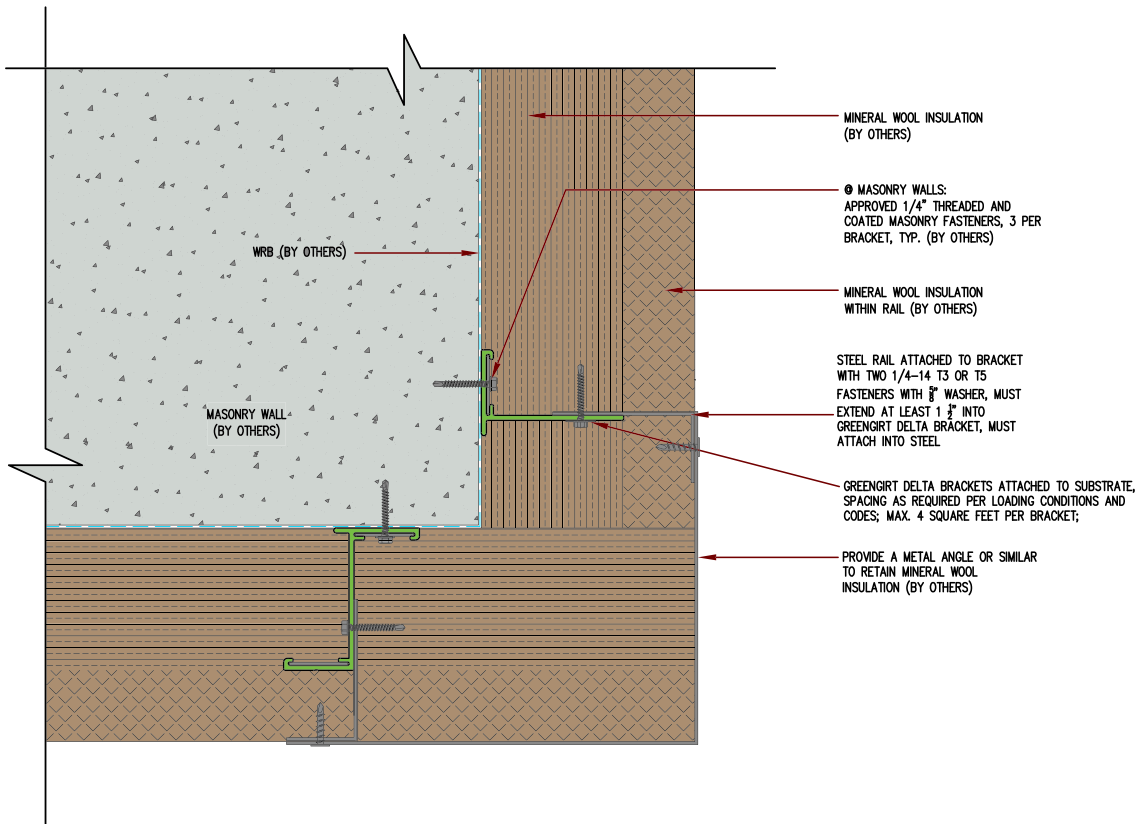

GreenGirt Delta
COMPOSITE METAL HYBRID ADJUSTABLE SYSTEM

GreenGirt.com

(269) 355-1818

SUBSTRATE: MASONRY

INSULATION: MINERAL WOOL

CLADDING:

DATE

GREENGIRT DELTA BRACKET SIZE: 300 / 3"

ORIENTATION: VERTICAL Z-BRACKET

OUTSIDE CORNER DETAIL

NOT TO SCALE

5

13D. Masonry - Header Detail



NOTE: DETAILS ARE PROVIDED FOR INFORMATION ONLY, AND ARE SUBJECT TO CHANGE WITHOUT NOTICE. SPECIFIC PROJECT ENGINEERING BY OTHERS WILL ADDRESS ATTACHMENT SPACING, ORIENTATION AND LOADING. CONTACT ADVANCED ARCHITECTURAL PRODUCTS FOR FURTHER DETAILS, AND TO INQUIRE ABOUT UPDATES AND REVISIONS. ADVANCED ARCHITECTURAL PRODUCTS IS ONLY RESPONSIBLE FOR THE THERMAL EXPANSION OF THE SUBFRAMING OF THE ADJUSTABLE SYSTEM. THE CLADDING MANUFACTURER IS RESPONSIBLE FOR HANDLING THERMAL EXPANSION OF THE CLADDING AS WELL AS THERMAL EXPANSION COMPATIBILITY WITH THE ADJUSTABLE SUBFRAMING.

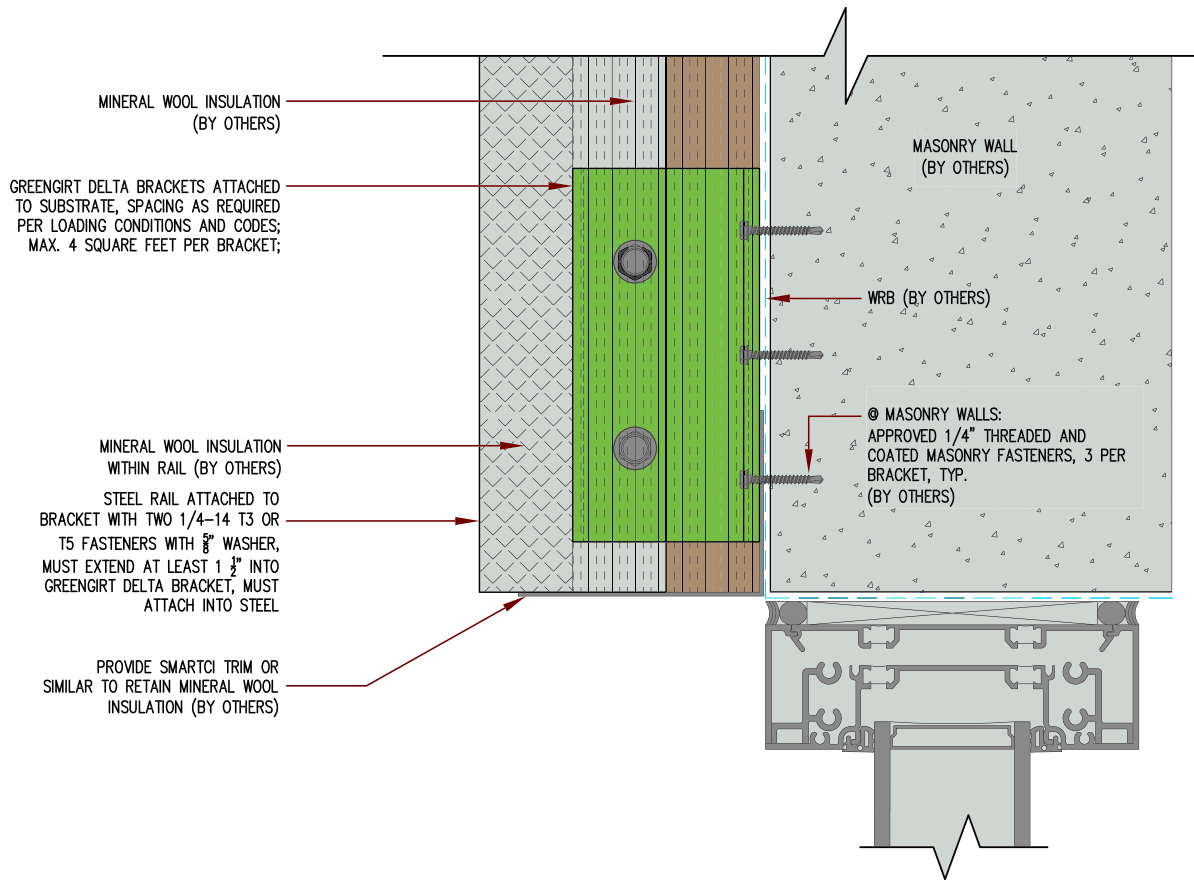

GreenGirt Delta™
COMPOSITE METAL HYBRID ADJUSTABLE SYSTEM

GreenGirt.com

(269) 355-1818

SUBSTRATE: MASONRY

INSULATION: MINERAL WOOL

CLADDING:

DATE

GREENGIRT DELTA BRACKET SIZE: 300 / 3"

ORIENTATION: VERTICAL Z-BRACKET

HEADER DETAIL

NOT TO SCALE

6

13E. Masonry - Jamb Detail



NOTE: DETAILS ARE PROVIDED FOR INFORMATION ONLY, AND ARE SUBJECT TO CHANGE WITHOUT NOTICE. SPECIFIC PROJECT ENGINEERING BY OTHERS WILL ADDRESS ATTACHMENT SPACING, ORIENTATION AND LOADING. CONTACT ADVANCED ARCHITECTURAL PRODUCTS FOR FURTHER DETAILS, AND TO INQUIRE ABOUT UPDATES AND REVISIONS. ADVANCED ARCHITECTURAL PRODUCTS IS ONLY RESPONSIBLE FOR THE THERMAL EXPANSION OF THE SUBFRAMING OF THE ADJUSTABLE SYSTEM. THE CLADDING MANUFACTURER IS RESPONSIBLE FOR HANDLING THERMAL EXPANSION OF THE CLADDING AS WELL AS THERMAL EXPANSION COMPATIBILITY WITH THE ADJUSTABLE SUBFRAMING.

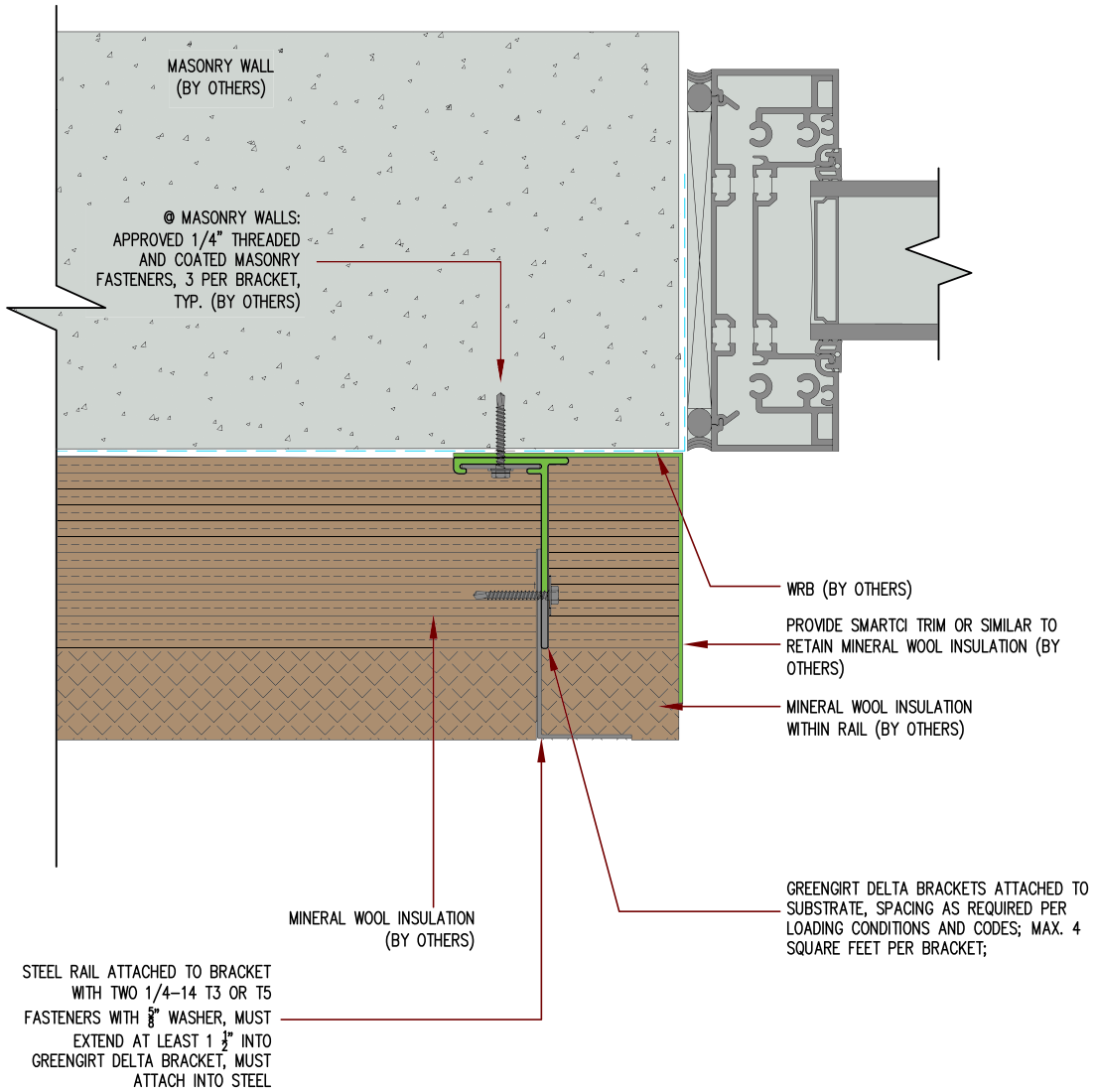

GreenGirt Delta™
COMPOSITE METAL HYBRID ADJUSTABLE SYSTEM

GreenGirt.com

(269) 355-1818

SUBSTRATE: MASONRY

INSULATION: MINERAL WOOL

CLADDING:

DATE

GREENGIRT DELTA BRACKET SIZE: 300 / 3"

ORIENTATION: VERTICAL Z-BRACKET

JAMB DETAIL

NOT TO SCALE

7

13F. Masonry - Sill Detail



NOTE: DETAILS ARE PROVIDED FOR INFORMATION ONLY, AND ARE SUBJECT TO CHANGE WITHOUT NOTICE. SPECIFIC PROJECT ENGINEERING BY OTHERS WILL ADDRESS ATTACHMENT SPACING, ORIENTATION AND LOADING. CONTACT ADVANCED ARCHITECTURAL PRODUCTS FOR FURTHER DETAILS, AND TO INQUIRE ABOUT UPDATES AND REVISIONS. ADVANCED ARCHITECTURAL PRODUCTS IS ONLY RESPONSIBLE FOR THE THERMAL EXPANSION OF THE SUBFRAMING OF THE ADJUSTABLE SYSTEM. THE CLADDING MANUFACTURER IS RESPONSIBLE FOR HANDLING THERMAL EXPANSION OF THE CLADDING AS WELL AS THERMAL EXPANSION COMPATIBILITY WITH THE ADJUSTABLE SUBFRAMING.

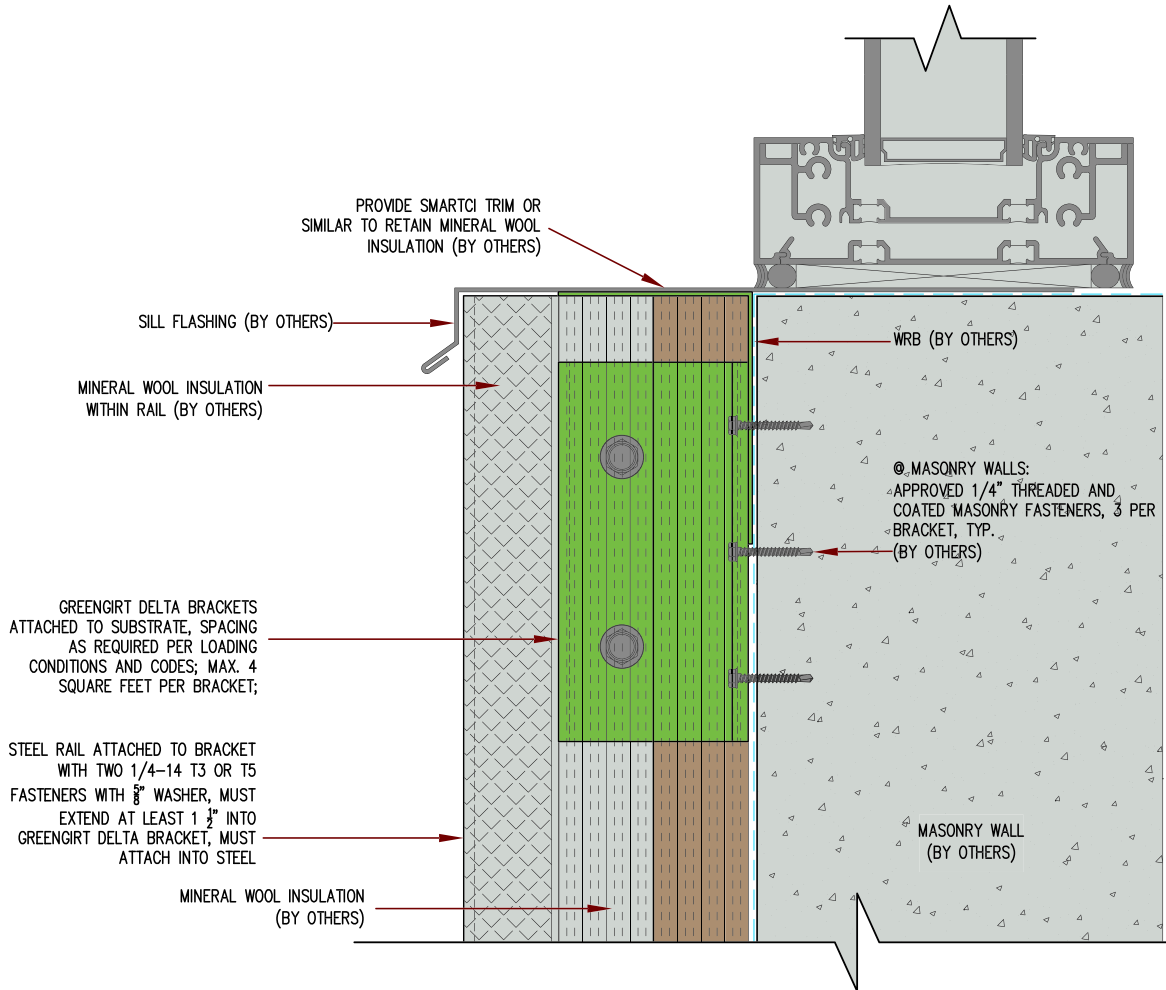

GreenGirt Delta™
COMPOSITE METAL HYBRID ADJUSTABLE SYSTEM

GreenGirt.com

(269) 355-1818

SUBSTRATE: MASONRY

INSULATION: MINERAL WOOL

CLADDING:

DATE

GREENGIRT DELTA BRACKET SIZE: 300 / 3"

ORIENTATION: VERTICAL Z-BRACKET

SILL DETAIL

NOT TO SCALE

7

13G. Masonry - Delta Slider with Steel L-Rail



NOTE: DETAILS ARE PROVIDED FOR INFORMATION ONLY, AND ARE SUBJECT TO CHANGE WITHOUT NOTICE. SPECIFIC PROJECT ENGINEERING BY OTHERS WILL ADDRESS ATTACHMENT SPACING, ORIENTATION AND LOADING. CONTACT ADVANCED ARCHITECTURAL PRODUCTS FOR FURTHER DETAILS, AND TO INQUIRE ABOUT UPDATES AND REVISIONS. ADVANCED ARCHITECTURAL PRODUCTS IS ONLY RESPONSIBLE FOR THE THERMAL EXPANSION OF THE SUBFRAMING OF THE ADJUSTABLE SYSTEM. THE CLADDING MANUFACTURER IS RESPONSIBLE FOR HANDLING THERMAL EXPANSION OF THE CLADDING AS WELL AS THERMAL EXPANSION COMPATIBILITY WITH THE ADJUSTABLE SUBFRAMING.

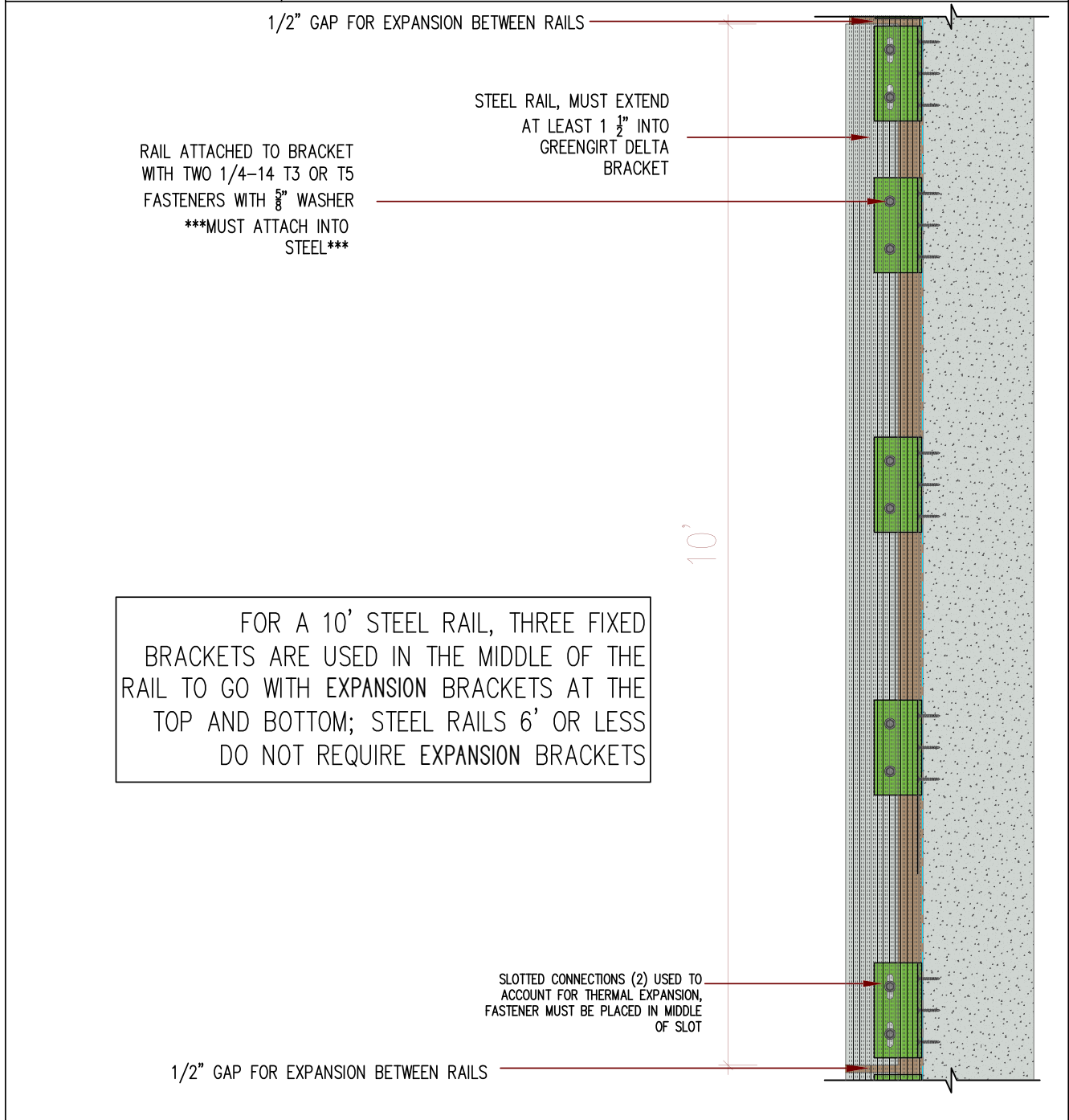

FOR A 10' STEEL RAIL, THREE FIXED BRACKETS ARE USED IN THE MIDDLE OF THE RAIL TO GO WITH EXPANSION BRACKETS AT THE TOP AND BOTTOM; STEEL RAILS 6' OR LESS DO NOT REQUIRE EXPANSION BRACKETS

| | | |
|---|--|---------------------------------|
| <p>COMPOSITE METAL HYBRID ADJUSTABLE SYSTEM</p> <p>GreenGirt.com (269) 355-1818</p> | SUBSTRATE: MASONRY | INSULATION: MINERAL WOOL |
| | CLADDING: | DATE |
| | GREENGIRT DELTA BRACKET SIZE: 300 / 3" | ORIENTATION: VERTICAL Z-BRACKET |
| <h2>DELTA W STEEL</h2> <p>NOT TO SCALE</p> | | |

13H. Masonry - Delta Slider with Aluminum L-Rail



NOTE: DETAILS ARE PROVIDED FOR INFORMATION ONLY, AND ARE SUBJECT TO CHANGE WITHOUT NOTICE. SPECIFIC PROJECT ENGINEERING BY OTHERS WILL ADDRESS ATTACHMENT SPACING, ORIENTATION AND LOADING. CONTACT ADVANCED ARCHITECTURAL PRODUCTS FOR FURTHER DETAILS, AND TO INQUIRE ABOUT UPDATES AND REVISIONS. ADVANCED ARCHITECTURAL PRODUCTS IS ONLY RESPONSIBLE FOR THE THERMAL EXPANSION OF THE SUBFRAMING OF THE ADJUSTABLE SYSTEM. THE CLADDING MANUFACTURER IS RESPONSIBLE FOR HANDLING THERMAL EXPANSION OF THE CLADDING AS WELL AS THERMAL EXPANSION COMPATIBILITY WITH THE ADJUSTABLE SUBFRAMING.

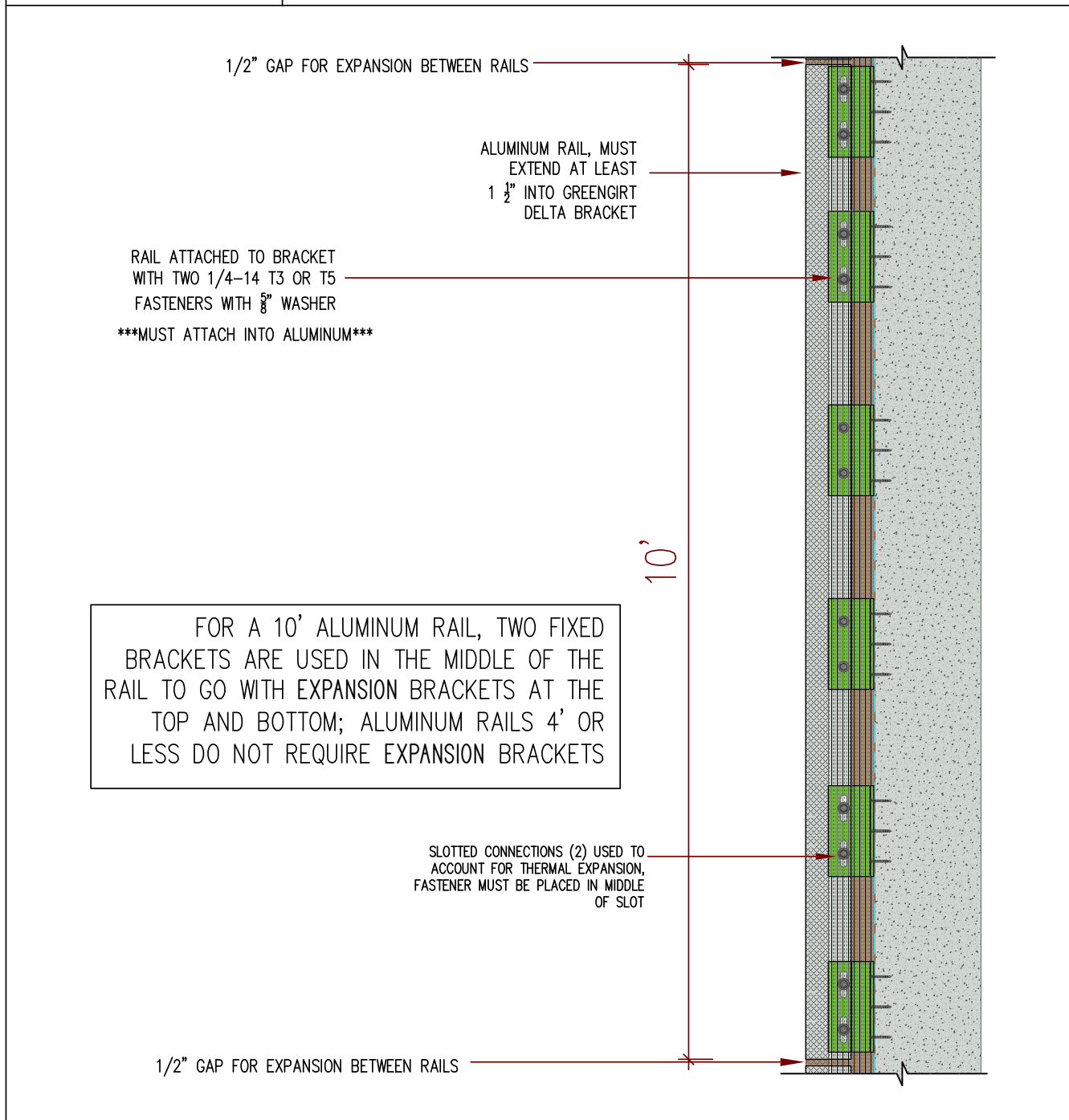

| | | |
|---|---|---------------------------------|
| <p>COMPOSITE METAL HYBRID ADJUSTABLE SYSTEM</p> <p>GreenGirt.com (269) 355-1818</p> | SUBSTRATE: MASONRY | INSULATION: MINERAL WOOL |
| | CLADDING: | DATE |
| | GREENGIRT DELTA BRACKET SIZE: 300 / 3" | ORIENTATION: VERTICAL Z-BRACKET |
| | <h2>DELTA W ALUMINUM</h2> <p>NOT TO SCALE</p> | |

13I. Masonry - Delta Slider (Bottom of L-Rail)



NOTE: DETAILS ARE PROVIDED FOR INFORMATION ONLY, AND ARE SUBJECT TO CHANGE WITHOUT NOTICE. SPECIFIC PROJECT ENGINEERING BY OTHERS WILL ADDRESS ATTACHMENT SPACING, ORIENTATION AND BONDING. CONTACT ADVANCED ARCHITECTURAL PRODUCTS FOR FURTHER DETAILS, AND TO INQUIRE ABOUT WARRANTIES AND REVISIONS. ADVANCED ARCHITECTURAL PRODUCTS IS ONLY RESPONSIBLE FOR THE THERMAL EXPANSION OF THE SUBSTRATING OF THE ADJUSTABLE SYSTEM. THE CLADDING MANUFACTURER IS RESPONSIBLE FOR HANDLING THERMAL EXPANSION OF THE CLADDING AS WELL AS THERMAL EXPANSION COMPATIBILITY WITH THE ADJUSTABLE SUBSTRATING.

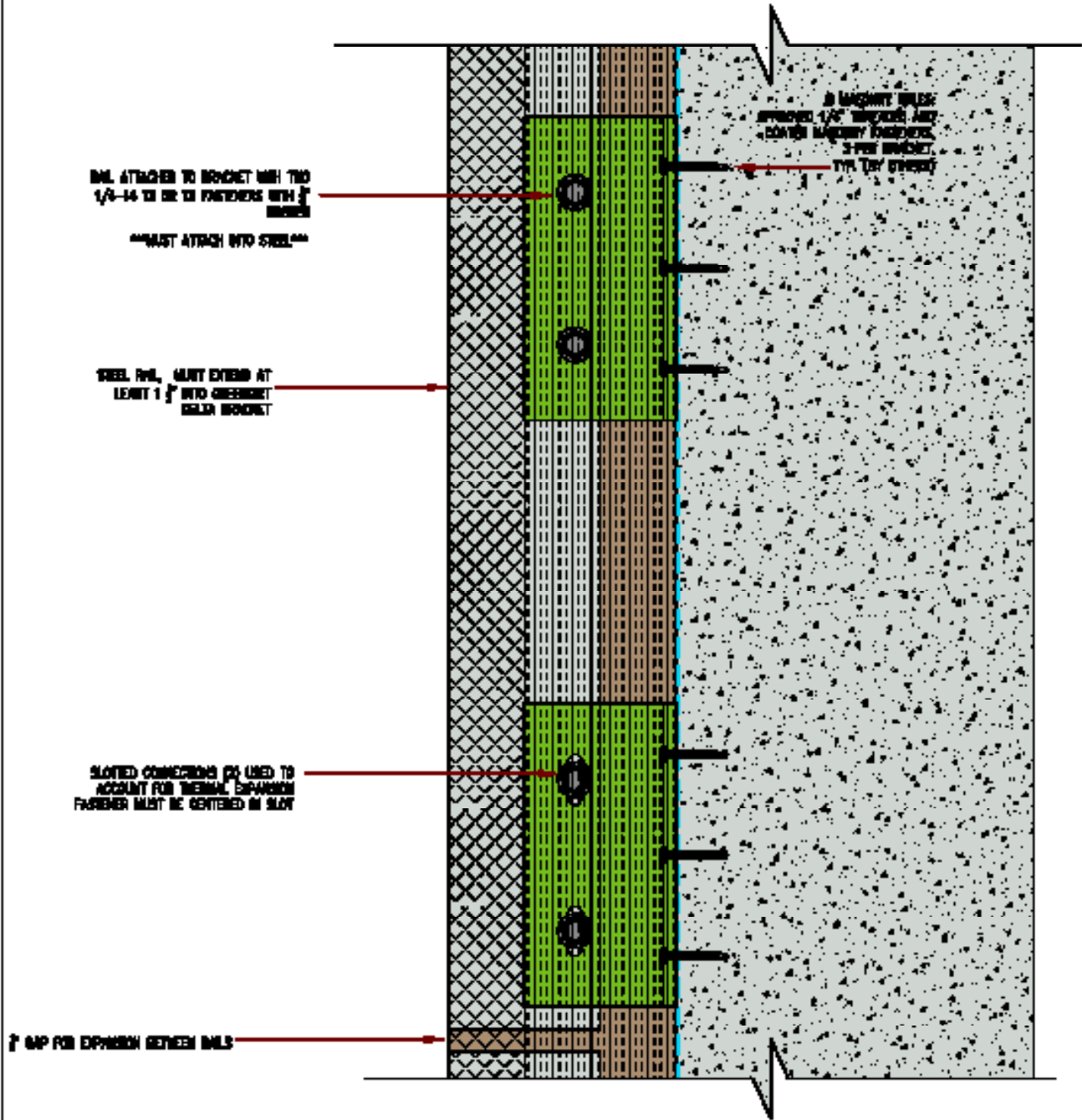

GreenGirt Delta
COMPOSITE METAL HYBRID ADJUSTABLE SYSTEM

GreenGirt.com

(209) 255-7878

| | |
|--|---------------------------------|
| SUBSTRATE: MASONRY | INSULATION: MINERAL WOOL |
| CLADDING: | DATE |
| GREENGIRT DELTA BRACKET SIZE: 300 / 3" | ORIENTATION: VERTICAL Z-BRACKET |

DELTA SLIDER (BTM OF RAIL)

NOT TO SCALE

13J. Masonry - Delta Slider (Floor Joint)



NOTE: DETAILS ARE PROVIDED FOR INFORMATION ONLY, AND ARE SUBJECT TO CHANGE WITHOUT NOTICE. SPECIFIC PROJECT ENGINEERING BY OTHERS WILL ADDRESS ATTACHMENT SPACING, ORIENTATION AND LOADING. CONTACT ADVANCED ARCHITECTURAL PRODUCTS FOR FURTHER DETAILS, AND TO INQUIRE ABOUT UPDATES AND REVISIONS. ADVANCED ARCHITECTURAL PRODUCTS IS ONLY RESPONSIBLE FOR THE THERMAL EXPANSION OF THE SUBFRAMING OF THE ADJUSTABLE SYSTEM. THE CLADDING MANUFACTURER IS RESPONSIBLE FOR HANDLING THERMAL EXPANSION OF THE CLADDING AS WELL AS THERMAL EXPANSION COMPATIBILITY WITH THE ADJUSTABLE SUBFRAMING.

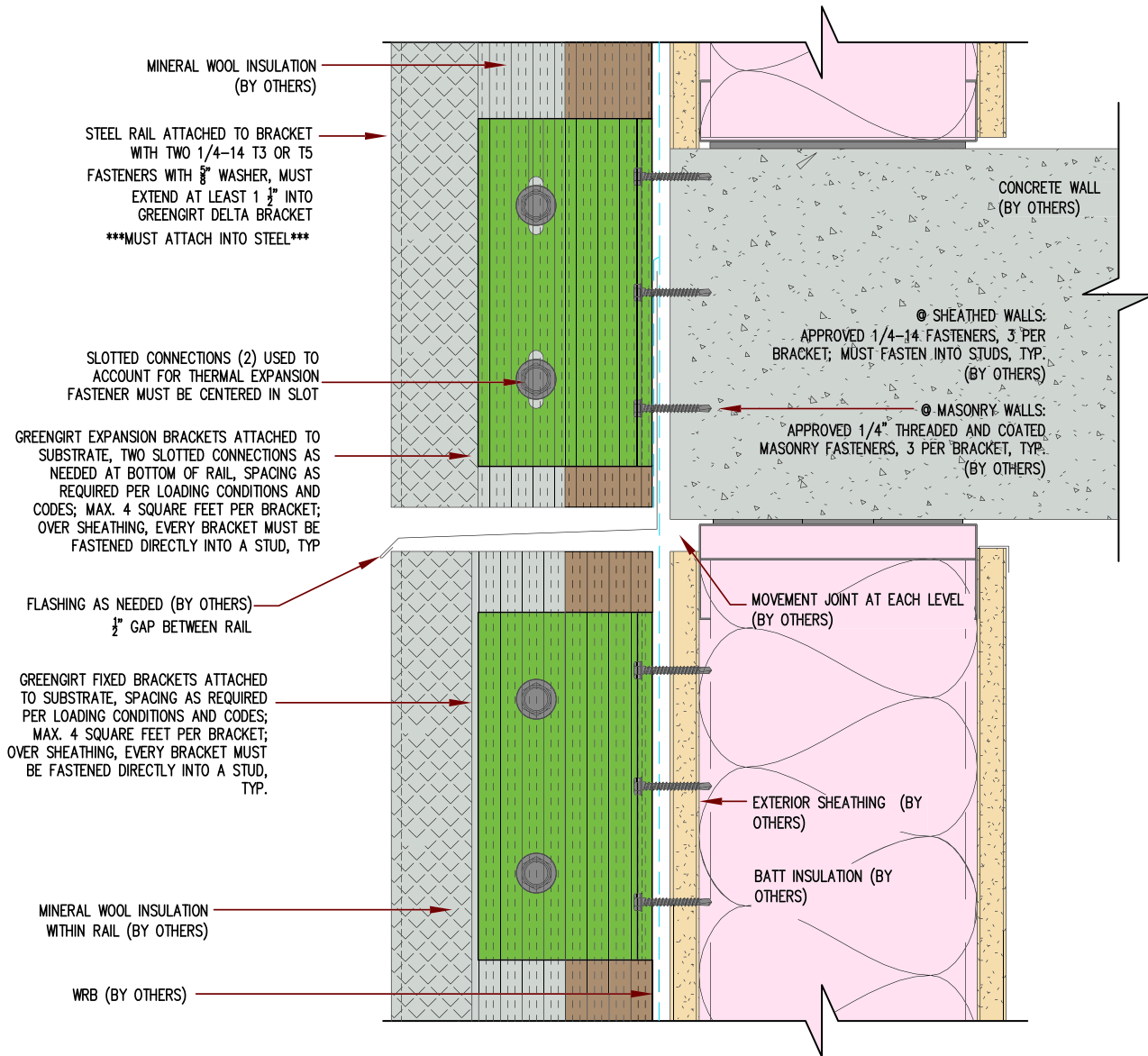

GreenGirt Delta™
COMPOSITE METAL HYBRID ADJUSTABLE SYSTEM

GreenGirt.com

(269) 355-1818

| | |
|--|---------------------------------|
| SUBSTRATE: MASONRY | INSULATION: MINERAL WOOL |
| CLADDING: | DATE |
| GREENGIRT DELTA BRACKET SIZE: 300 / 3" | ORIENTATION: VERTICAL Z-BRACKET |

DELTA SLIDER (FLOOR JOINT)

NOT TO SCALE

14A. Construction Details on Studs (Vertical) - Wall Section



NOTE: DETAILS ARE PROVIDED FOR INFORMATION ONLY, AND ARE SUBJECT TO CHANGE WITHOUT NOTICE. SPECIFIC PROJECT ENGINEERING BY OTHERS WILL ADDRESS ATTACHMENT SPACING, ORIENTATION AND LOADING. CONTACT ADVANCED ARCHITECTURAL PRODUCTS FOR FURTHER DETAILS, AND TO INQUIRE ABOUT UPDATES AND REVISIONS. ADVANCED ARCHITECTURAL PRODUCTS IS ONLY RESPONSIBLE FOR THE THERMAL EXPANSION OF THE SUBFRAMING OF THE ADJUSTABLE SYSTEM. THE CLADDING MANUFACTURER IS RESPONSIBLE FOR HANDLING THERMAL EXPANSION OF THE CLADDING AS WELL AS THERMAL EXPANSION COMPATIBILITY WITH THE ADJUSTABLE SUBFRAMING.

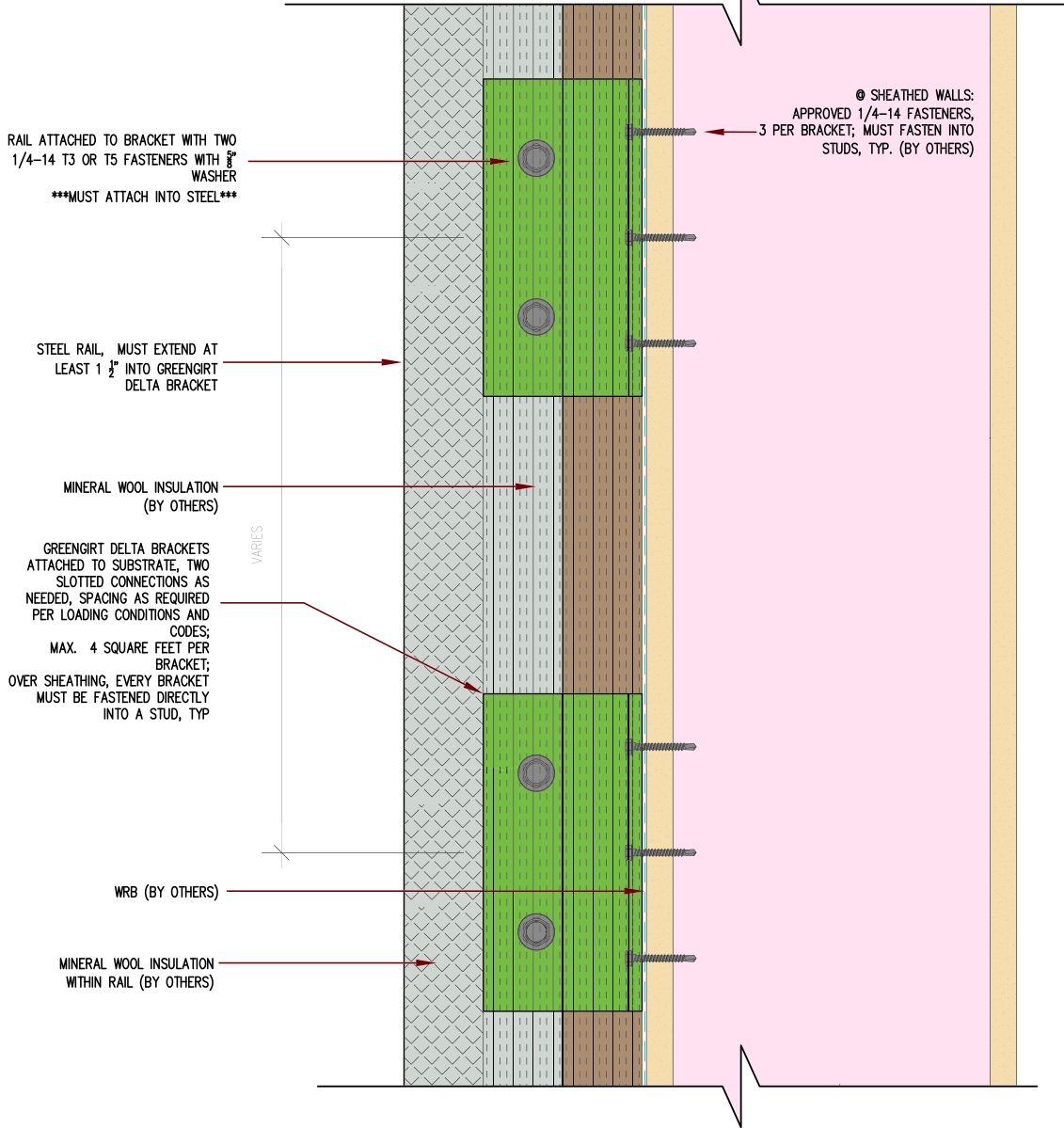

GreenGirt Delta™
COMPOSITE METAL HYBRID ADJUSTABLE SYSTEM

GreenGirt.com

(269) 355-1818

| | |
|---|---------------------------------|
| SUBSTRATE: SHEATHING W/ METAL STUD | INSULATION: MINERAL WOOL |
| CLADDING: | DATE |
| GREENGIRT DELTA BRACKET SIZE: 300 / 3" | ORIENTATION: VERTICAL Z-BRACKET |

3" STEEL RAIL WITH 3" DELTA

NOT TO SCALE

14B. Studs - Inside Corner Detail



NOTE: DETAILS ARE PROVIDED FOR INFORMATION ONLY, AND ARE SUBJECT TO CHANGE WITHOUT NOTICE. SPECIFIC PROJECT ENGINEERING BY OTHERS WILL ADDRESS ATTACHMENT SPACING, ORIENTATION AND LOADING. CONTACT ADVANCED ARCHITECTURAL PRODUCTS FOR FURTHER DETAILS, AND TO INQUIRE ABOUT UPDATES AND REVISIONS. ADVANCED ARCHITECTURAL PRODUCTS IS ONLY RESPONSIBLE FOR THE THERMAL EXPANSION OF THE SUBFRAMING OF THE ADJUSTABLE SYSTEM. THE CLADDING MANUFACTURER IS RESPONSIBLE FOR HANDLING THERMAL EXPANSION OF THE CLADDING AS WELL AS THERMAL EXPANSION COMPATIBILITY WITH THE ADJUSTABLE SUBFRAMING.

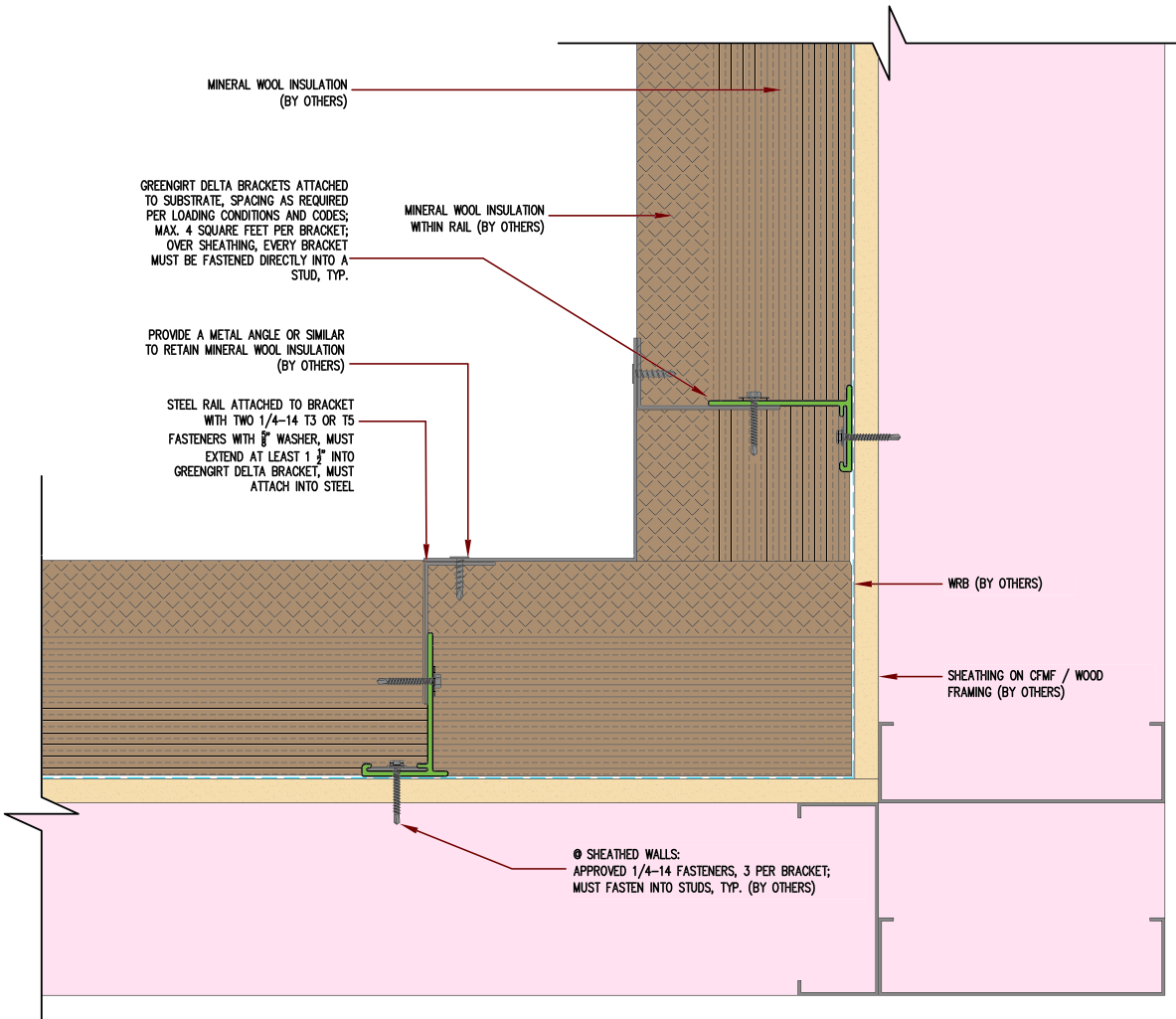

GreenGirt Delta™
COMPOSITE METAL HYBRID ADJUSTABLE SYSTEM

GreenGirt.com

(269) 355-1818

SUBSTRATE: SHEATHING W/ METAL STUD

INSULATION: MINERAL WOOL

CLADDING:

DATE

GREENGIRT DELTA BRACKET SIZE: 300 / 3"

ORIENTATION: VERTICAL Z-BRACKET

INSIDE CORNER DETAIL

NOT TO SCALE

4

14C. Studs - Outside Corner Detail



NOTE: DETAILS ARE PROVIDED FOR INFORMATION ONLY, AND ARE SUBJECT TO CHANGE WITHOUT NOTICE. SPECIFIC PROJECT ENGINEERING BY OTHERS WILL ADDRESS ATTACHMENT SPACING, ORIENTATION AND LOADING. CONTACT ADVANCED ARCHITECTURAL PRODUCTS FOR FURTHER DETAILS, AND TO INQUIRE ABOUT UPDATES AND REVISIONS. ADVANCED ARCHITECTURAL PRODUCTS IS ONLY RESPONSIBLE FOR THE THERMAL EXPANSION OF THE SUBFRAMING OF THE ADJUSTABLE SYSTEM. THE CLADDING MANUFACTURER IS RESPONSIBLE FOR HANDLING THERMAL EXPANSION OF THE CLADDING AS WELL AS THERMAL EXPANSION COMPATIBILITY WITH THE ADJUSTABLE SUBFRAMING.

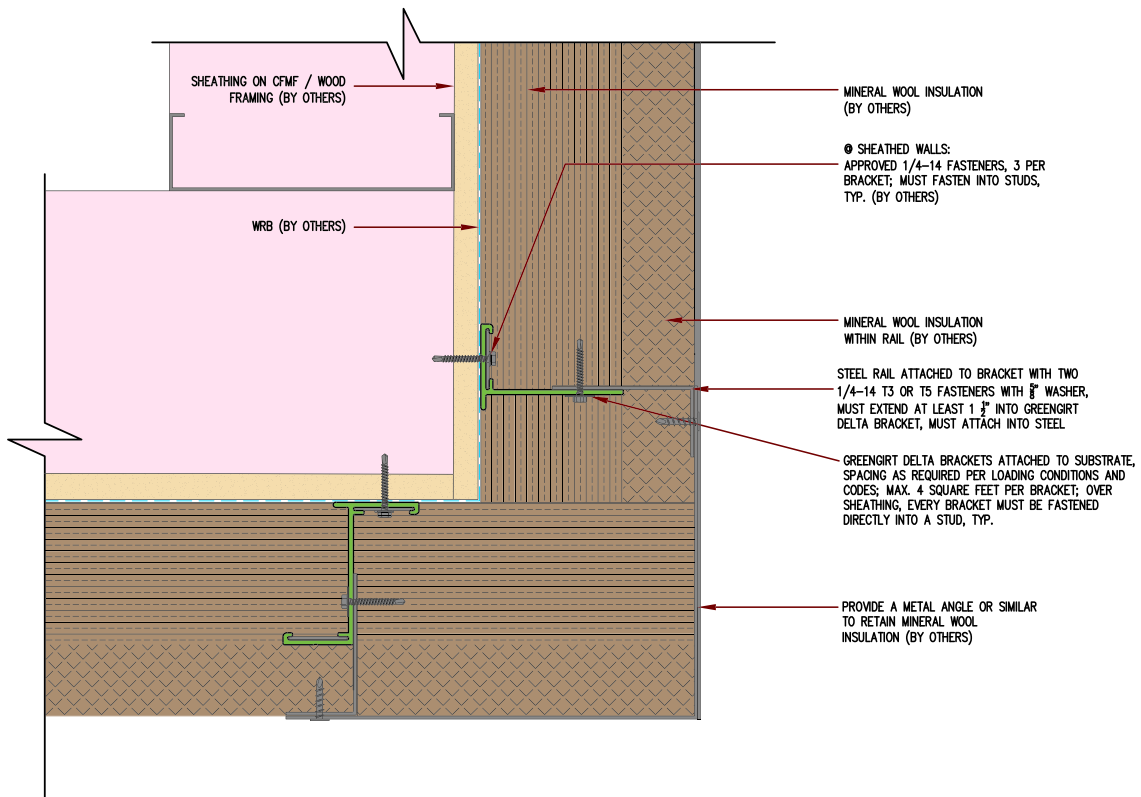

GreenGirt Delta[™]
COMPOSITE METAL HYBRID ADJUSTABLE SYSTEM

GreenGirt.com

(269) 355-1818

SUBSTRATE: SHEATHING W/ METAL STUD

INSULATION: MINERAL WOOL

CLADDING:

DATE

GREENGIRT DELTA BRACKET SIZE: 300 / 3"

ORIENTATION: VERTICAL Z-BRACKET

OUTSIDE CORNER DETAIL

NOT TO SCALE

5

14D. Studs - Header Detail



NOTE: DETAILS ARE PROVIDED FOR INFORMATION ONLY, AND ARE SUBJECT TO CHANGE WITHOUT NOTICE. SPECIFIC PROJECT ENGINEERING BY OTHERS WILL ADDRESS ATTACHMENT SPACING, ORIENTATION AND LOADING. CONTACT ADVANCED ARCHITECTURAL PRODUCTS FOR FURTHER DETAILS, AND TO INQUIRE ABOUT UPDATES AND REVISIONS. ADVANCED ARCHITECTURAL PRODUCTS IS ONLY RESPONSIBLE FOR THE THERMAL EXPANSION OF THE SUBFRAMING OF THE ADJUSTABLE SYSTEM. THE CLADDING MANUFACTURER IS RESPONSIBLE FOR HANDLING THERMAL EXPANSION OF THE CLADDING AS WELL AS THERMAL EXPANSION COMPATIBILITY WITH THE ADJUSTABLE SUBFRAMING.

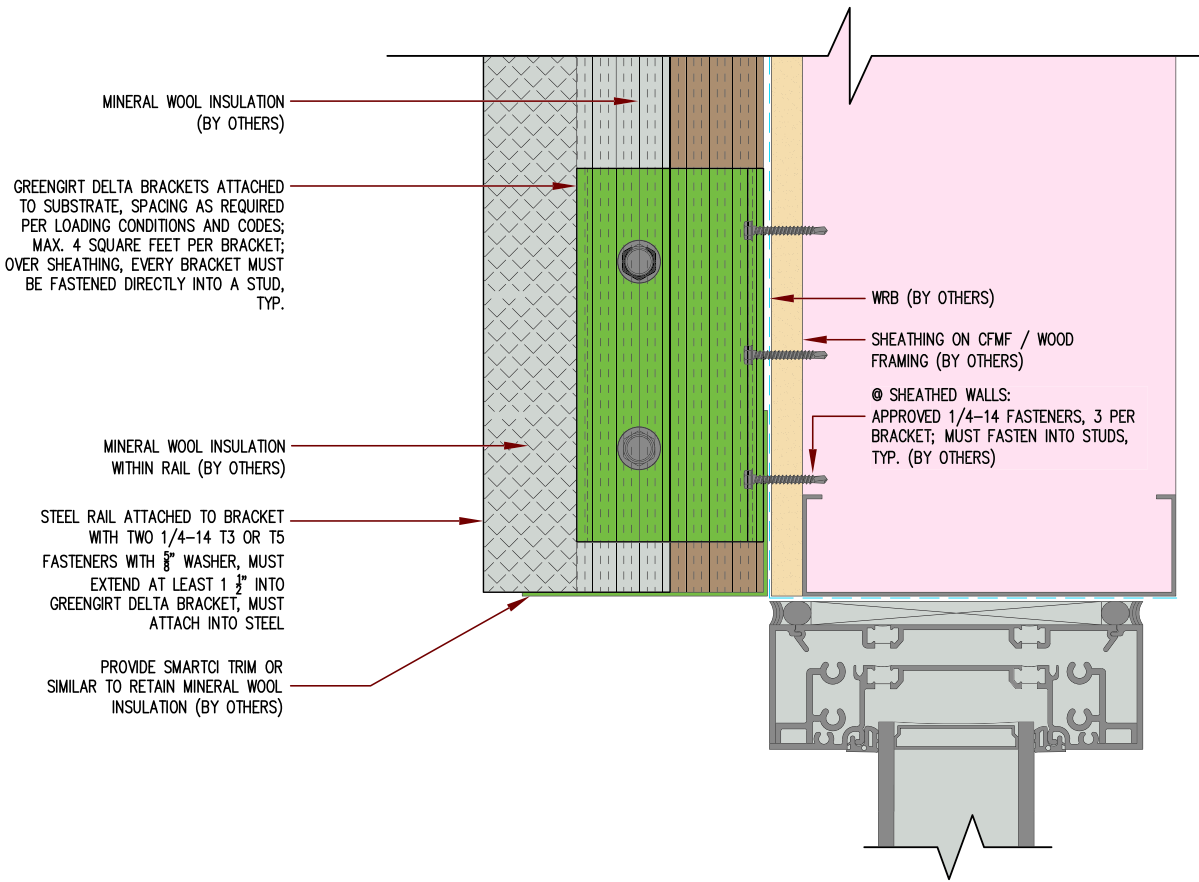

GreenGirt Delta™
COMPOSITE METAL HYBRID ADJUSTABLE SYSTEM

GreenGirt.com

(269) 355-1818

SUBSTRATE: SHEATHING W/ METAL STUD

INSULATION: MINERAL WOOL

CLADDING:

DATE

GREENGIRT DELTA BRACKET SIZE: 300 / 3"

ORIENTATION: VERTICAL Z-BRACKET

HEADER DETAIL

NOT TO SCALE

6

14E. Studs - Jamb Detail



NOTE: DETAILS ARE PROVIDED FOR INFORMATION ONLY, AND ARE SUBJECT TO CHANGE WITHOUT NOTICE. SPECIFIC PROJECT ENGINEERING BY OTHERS WILL ADDRESS ATTACHMENT SPACING, ORIENTATION AND LOADING. CONTACT ADVANCED ARCHITECTURAL PRODUCTS FOR FURTHER DETAILS, AND TO INQUIRE ABOUT UPDATES AND REVISIONS. ADVANCED ARCHITECTURAL PRODUCTS IS ONLY RESPONSIBLE FOR THE THERMAL EXPANSION OF THE SUBFRAMING OF THE ADJUSTABLE SYSTEM. THE CLADDING MANUFACTURER IS RESPONSIBLE FOR HANDLING THERMAL EXPANSION OF THE CLADDING AS WELL AS THERMAL EXPANSION COMPATIBILITY WITH THE ADJUSTABLE SUBFRAMING.

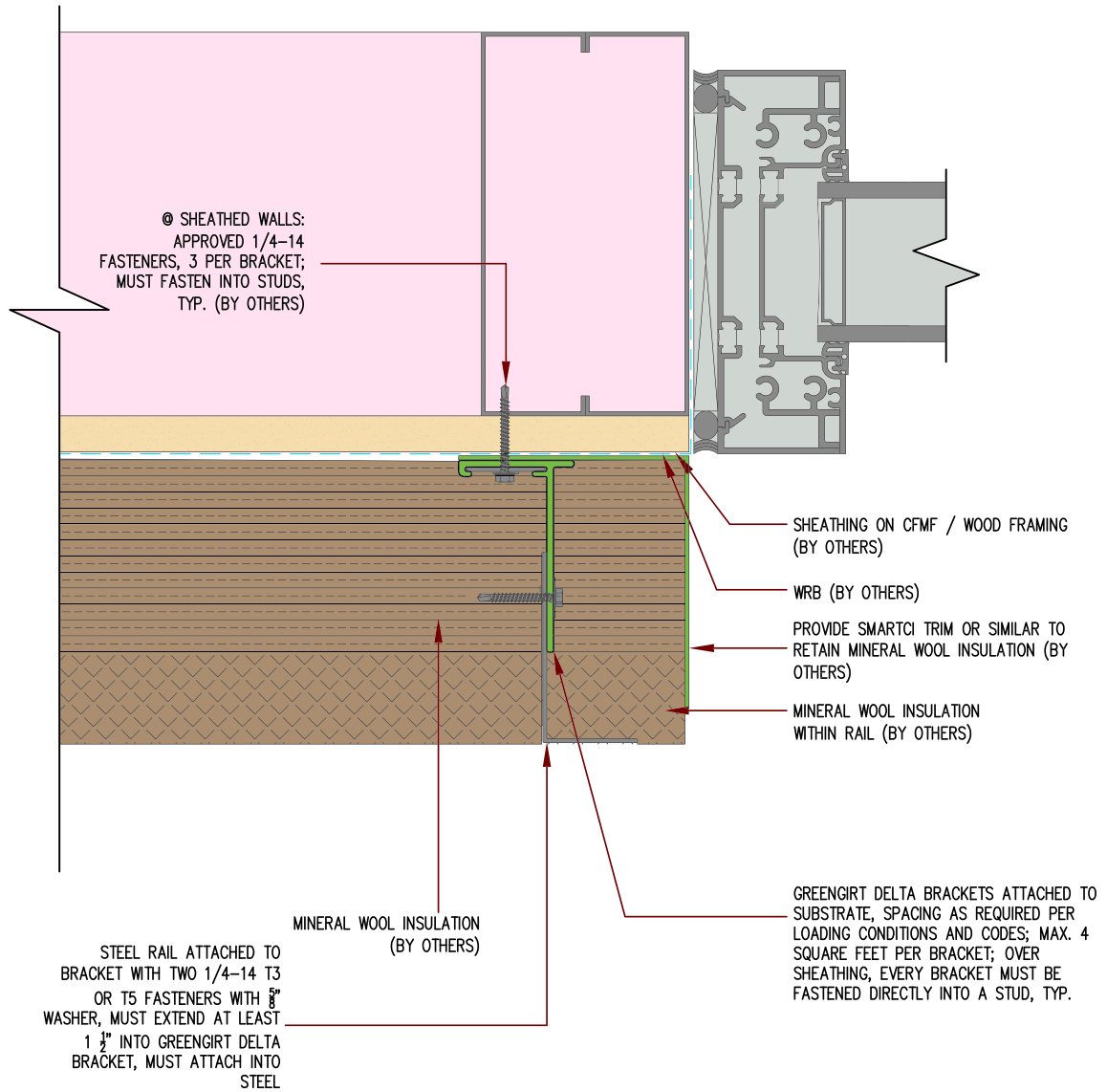

GreenGirt Delta™
COMPOSITE METAL HYBRID ADJUSTABLE SYSTEM

GreenGirt.com

(269) 355-1818

SUBSTRATE: SHEATHING W/ METAL STUD

INSULATION: MINERAL WOOL

CLADDING:

DATE

GREENGIRT DELTA BRACKET SIZE: 300 / 3"

ORIENTATION: VERTICAL Z-BRACKET

JAMB DETAIL

NOT TO SCALE

7

14F. Studs - Sill Detail



NOTE: DETAILS ARE PROVIDED FOR INFORMATION ONLY, AND ARE SUBJECT TO CHANGE WITHOUT NOTICE. SPECIFIC PROJECT ENGINEERING BY OTHERS WILL ADDRESS ATTACHMENT SPACING, ORIENTATION AND LOADING. CONTACT ADVANCED ARCHITECTURAL PRODUCTS FOR FURTHER DETAILS, AND TO INQUIRE ABOUT UPDATES AND REVISIONS. ADVANCED ARCHITECTURAL PRODUCTS IS ONLY RESPONSIBLE FOR THE THERMAL EXPANSION OF THE SUBFRAMING OF THE ADJUSTABLE SYSTEM. THE CLADDING MANUFACTURER IS RESPONSIBLE FOR HANDLING THERMAL EXPANSION OF THE CLADDING AS WELL AS THERMAL EXPANSION COMPATIBILITY WITH THE ADJUSTABLE SUBFRAMING.

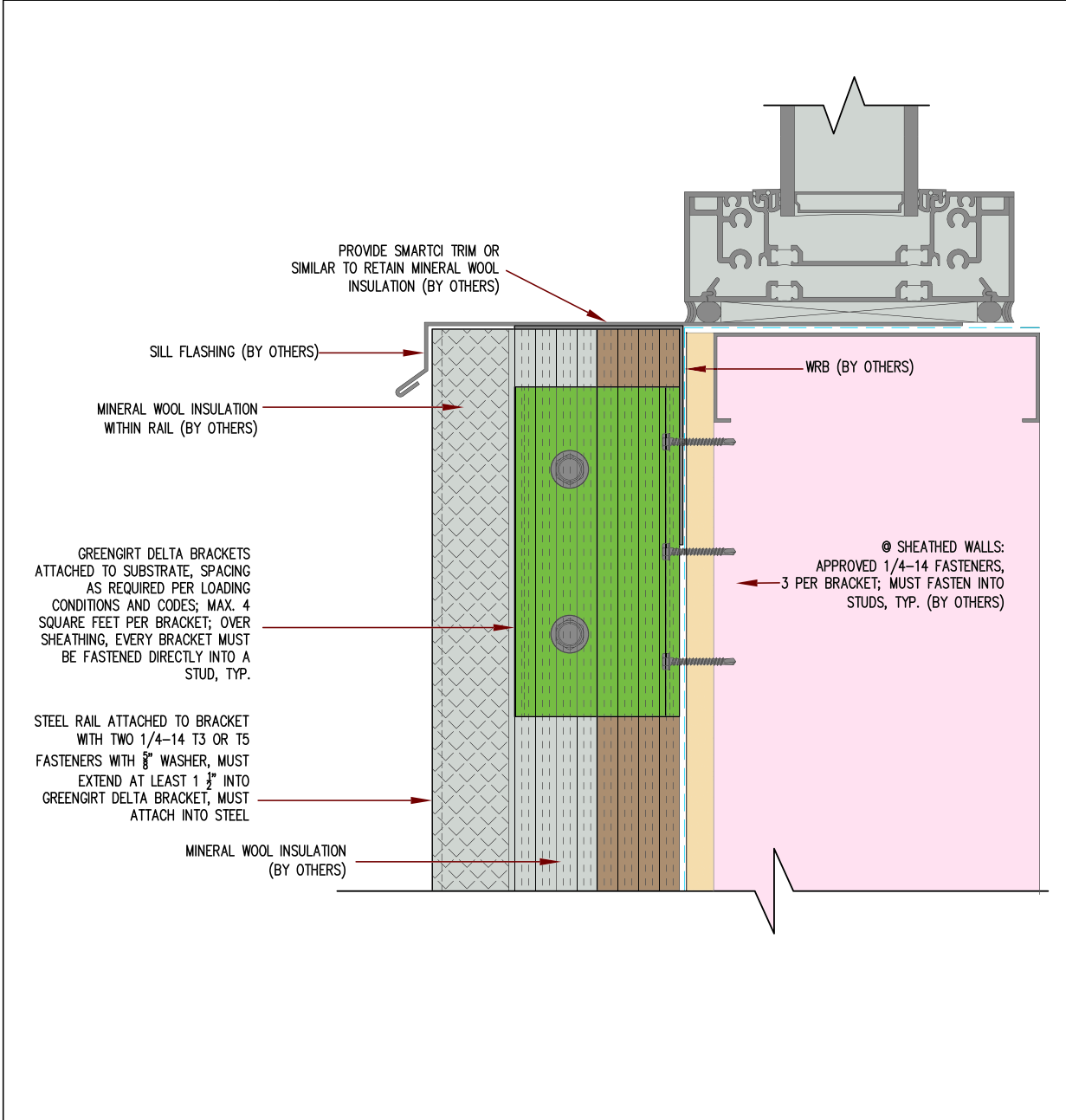

| | | |
|---|--|---------------------------------|
|  <p>COMPOSITE METAL HYBRID ADJUSTABLE SYSTEM</p> <p>GreenGirt.com (269) 355-1818</p> | SUBSTRATE: SHEATHING W/ METAL STUD | INSULATION: MINERAL WOOL |
| | CLADDING: | DATE |
| | GREENGIRT DELTA BRACKET SIZE: 300 / 3" | ORIENTATION: VERTICAL Z-BRACKET |
| <h2>SILL DETAIL</h2> <p>NOT TO SCALE</p> | | |
| 7 | | |

14G. Studs - Delta Slider with Steel L-Rail



NOTE: DETAILS ARE PROVIDED FOR INFORMATION ONLY, AND ARE SUBJECT TO CHANGE WITHOUT NOTICE. SPECIFIC PROJECT ENGINEERING BY OTHERS WILL ADDRESS ATTACHMENT SPACING, ORIENTATION AND LOADING. CONTACT ADVANCED ARCHITECTURAL PRODUCTS FOR FURTHER DETAILS, AND TO INQUIRE ABOUT UPDATES AND REVISIONS. ADVANCED ARCHITECTURAL PRODUCTS IS ONLY RESPONSIBLE FOR THE THERMAL EXPANSION OF THE SUBFRAMING OF THE ADJUSTABLE SYSTEM. THE CLADDING MANUFACTURER IS RESPONSIBLE FOR HANDLING THERMAL EXPANSION OF THE CLADDING AS WELL AS THERMAL EXPANSION COMPATIBILITY WITH THE ADJUSTABLE SUBFRAMING.

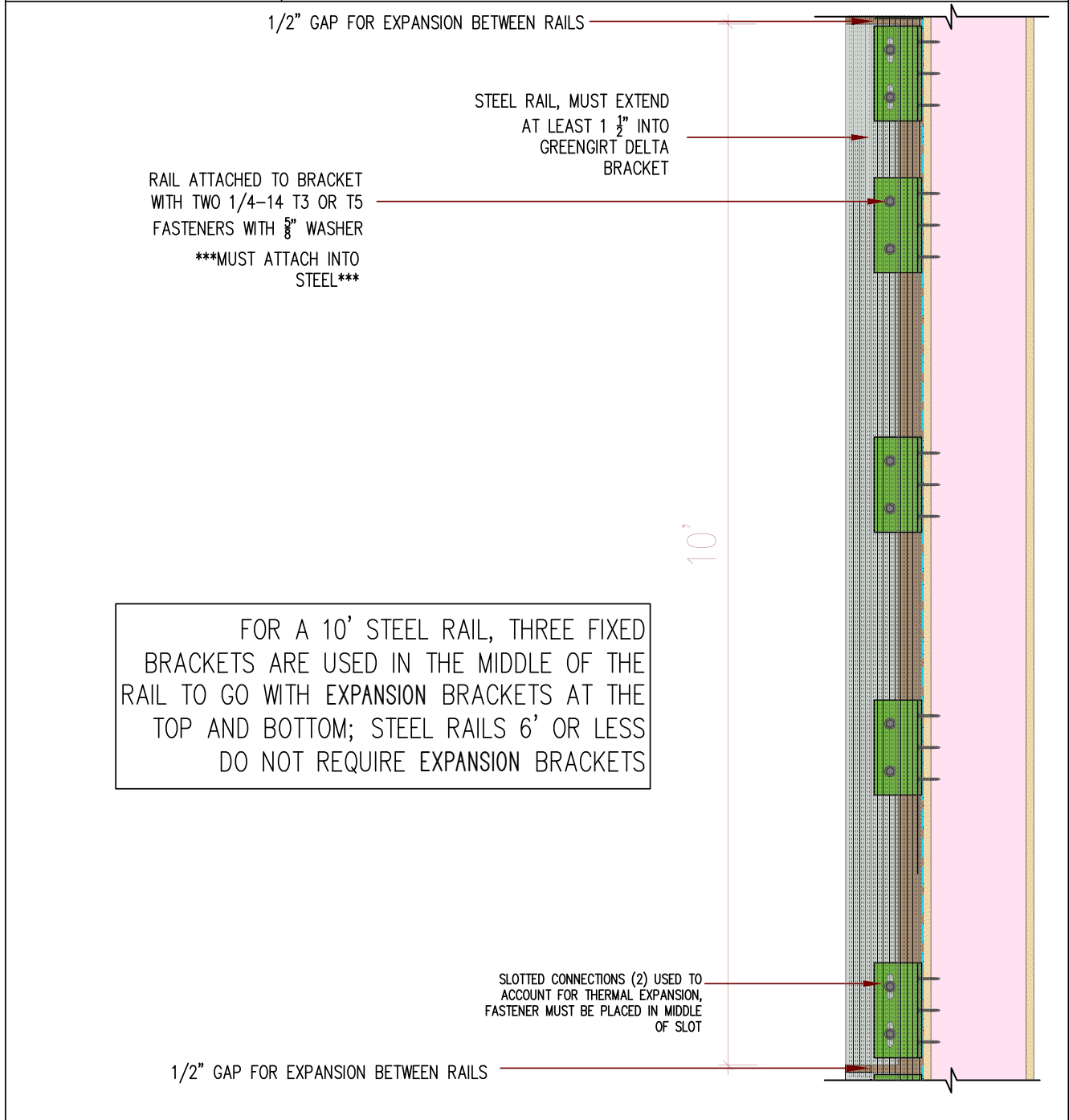

FOR A 10' STEEL RAIL, THREE FIXED BRACKETS ARE USED IN THE MIDDLE OF THE RAIL TO GO WITH EXPANSION BRACKETS AT THE TOP AND BOTTOM; STEEL RAILS 6' OR LESS DO NOT REQUIRE EXPANSION BRACKETS

| | | |
|---|---|---------------------------------|
| <p>COMPOSITE METAL HYBRID ADJUSTABLE SYSTEM</p> <p>GreenGirt.com (269) 355-1818</p> | SUBSTRATE: SHEATHING W/ METAL STUD | INSULATION: MINERAL WOOL |
| | CLADDING: | DATE |
| | GREENGIRT DELTA BRACKET SIZE: 300 / 3" | ORIENTATION: VERTICAL Z-BRACKET |
| <h2>DELTA W STEEL</h2> <p>NOT TO SCALE</p> | | |

14H. Studs - Delta Slider with Aluminum L-Rail



NOTE: DETAILS ARE PROVIDED FOR INFORMATION ONLY, AND ARE SUBJECT TO CHANGE WITHOUT NOTICE. SPECIFIC PROJECT ENGINEERING BY OTHERS WILL ADDRESS ATTACHMENT SPACING, ORIENTATION AND LOADING. CONTACT ADVANCED ARCHITECTURAL PRODUCTS FOR FURTHER DETAILS, AND TO INQUIRE ABOUT UPDATES AND REVISIONS. ADVANCED ARCHITECTURAL PRODUCTS IS ONLY RESPONSIBLE FOR THE THERMAL EXPANSION OF THE SUBFRAMING OF THE ADJUSTABLE SYSTEM. THE CLADDING MANUFACTURER IS RESPONSIBLE FOR HANDLING THERMAL EXPANSION OF THE CLADDING AS WELL AS THERMAL EXPANSION COMPATIBILITY WITH THE ADJUSTABLE SUBFRAMING.

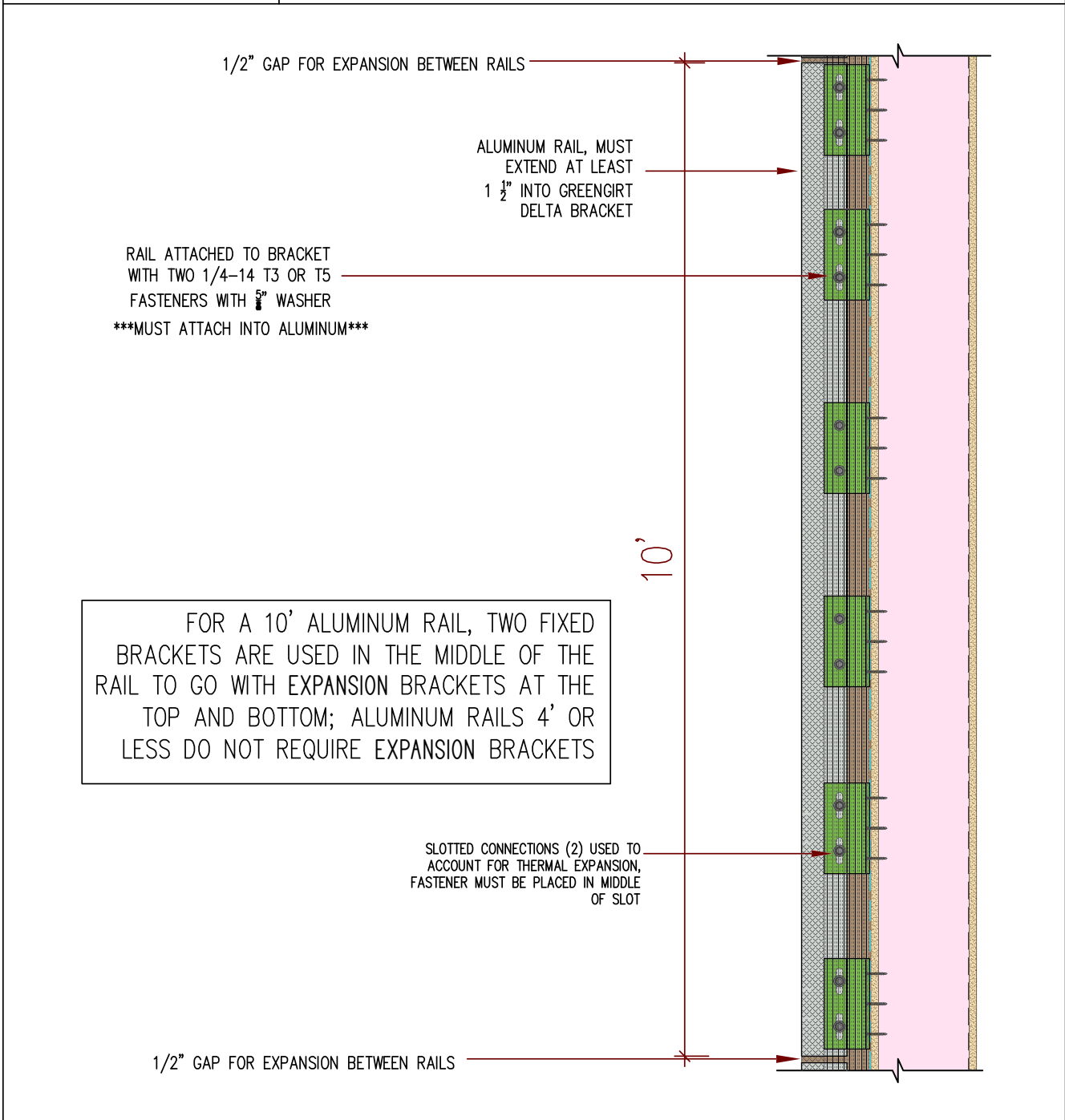

GreenGirt Delta
COMPOSITE METAL HYBRID ADJUSTABLE SYSTEM

GreenGirt.com

(269) 355-1818

| | |
|--|---------------------------------|
| SUBSTRATE: SHEATHING W/ METAL STUDS | INSULATION: MINERAL WOOL |
| CLADDING: | DATE |
| GREENGIRT DELTA BRACKET SIZE: 300 / 3" | ORIENTATION: VERTICAL Z-BRACKET |

DELTA W ALUMINUM

NOT TO SCALE

14I. Studs - Delta Slider (Bottom of L-Rail)



NOTE: DETAILS ARE PROVIDED FOR INFORMATION ONLY, AND ARE SUBJECT TO CHANGE WITHOUT NOTICE. SPECIFIC PROJECT ENGINEERING BY OTHERS WILL ADDRESS ATTACHMENT SPACING, ORIENTATION AND LOADING. CONTACT ADVANCED ARCHITECTURAL PRODUCTS FOR FURTHER DETAILS, AND TO INQUIRE ABOUT UPDATES AND REVISIONS. ADVANCED ARCHITECTURAL PRODUCTS IS ONLY RESPONSIBLE FOR THE THERMAL EXPANSION OF THE SUBFRAMING OF THE ADJUSTABLE SYSTEM. THE CLADDING MANUFACTURER IS RESPONSIBLE FOR HANDLING THERMAL EXPANSION OF THE CLADDING AS WELL AS THERMAL EXPANSION COMPATIBILITY WITH THE ADJUSTABLE SUBFRAMING.

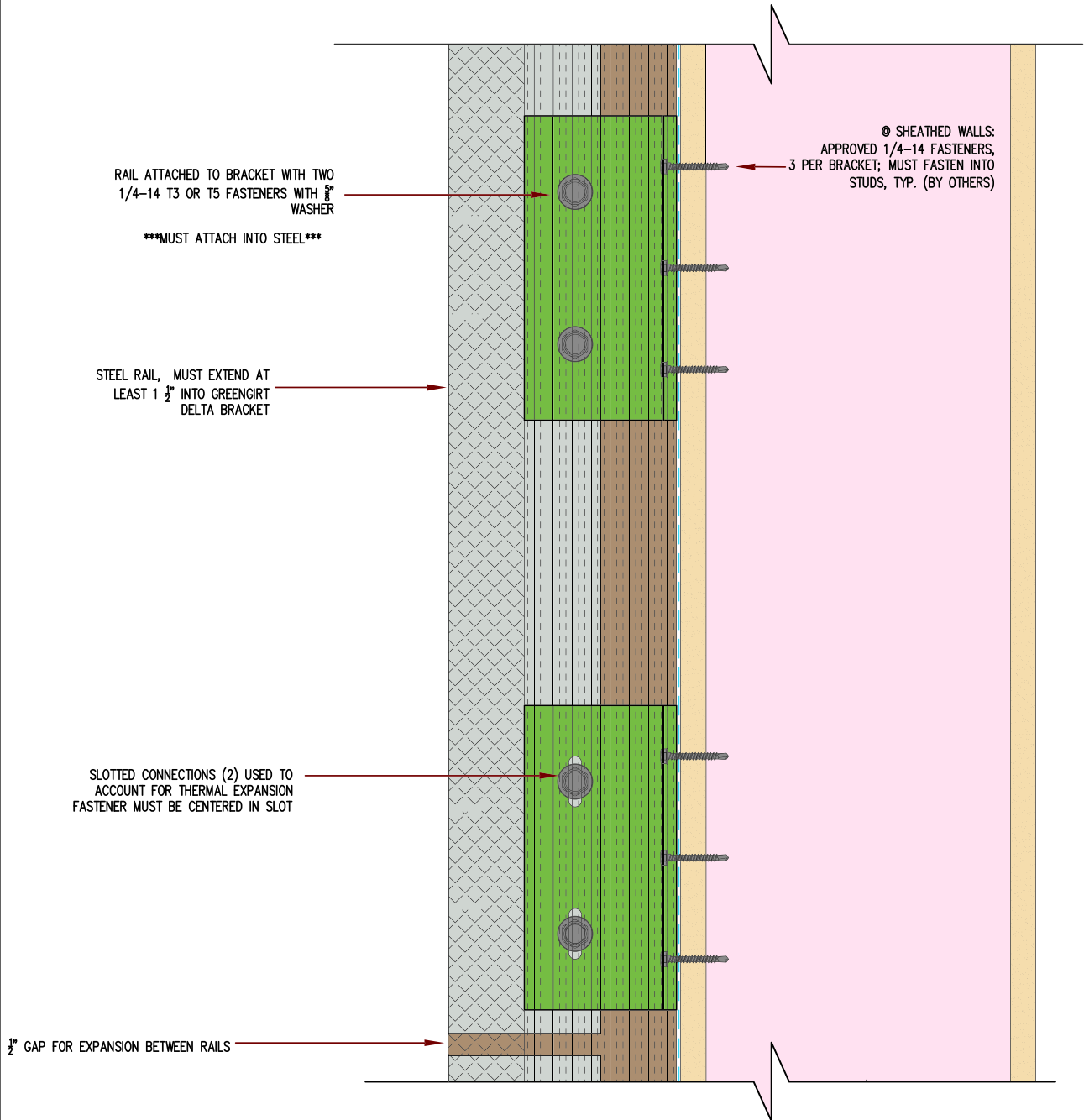

GreenGirt Delta™
 COMPOSITE METAL HYBRID ADJUSTABLE SYSTEM

GreenGirt.com

(269) 355-1818

SUBSTRATE: **SHEATHING W/ METAL STUD**

INSULATION: MINERAL WOOL

CLADDING:

DATE

GREENGIRT DELTA BRACKET SIZE: 300 / 3"

ORIENTATION: VERTICAL Z-BRACKET

DELTA SLIDER (BTM OF RAIL)

NOT TO SCALE

14J. Studs - Delta Slider (Floor Joint)



NOTE: DETAILS ARE PROVIDED FOR INFORMATION ONLY, AND ARE SUBJECT TO CHANGE WITHOUT NOTICE. SPECIFIC PROJECT ENGINEERING BY OTHERS WILL ADDRESS ATTACHMENT SPACING, ORIENTATION AND LOADING. CONTACT ADVANCED ARCHITECTURAL PRODUCTS FOR FURTHER DETAILS, AND TO INQUIRE ABOUT UPDATES AND REVISIONS. ADVANCED ARCHITECTURAL PRODUCTS IS ONLY RESPONSIBLE FOR THE THERMAL EXPANSION OF THE SUBFRAMING OF THE ADJUSTABLE SYSTEM. THE CLADDING MANUFACTURER IS RESPONSIBLE FOR HANDLING THERMAL EXPANSION OF THE CLADDING AS WELL AS THERMAL EXPANSION COMPATIBILITY WITH THE ADJUSTABLE SUBFRAMING.

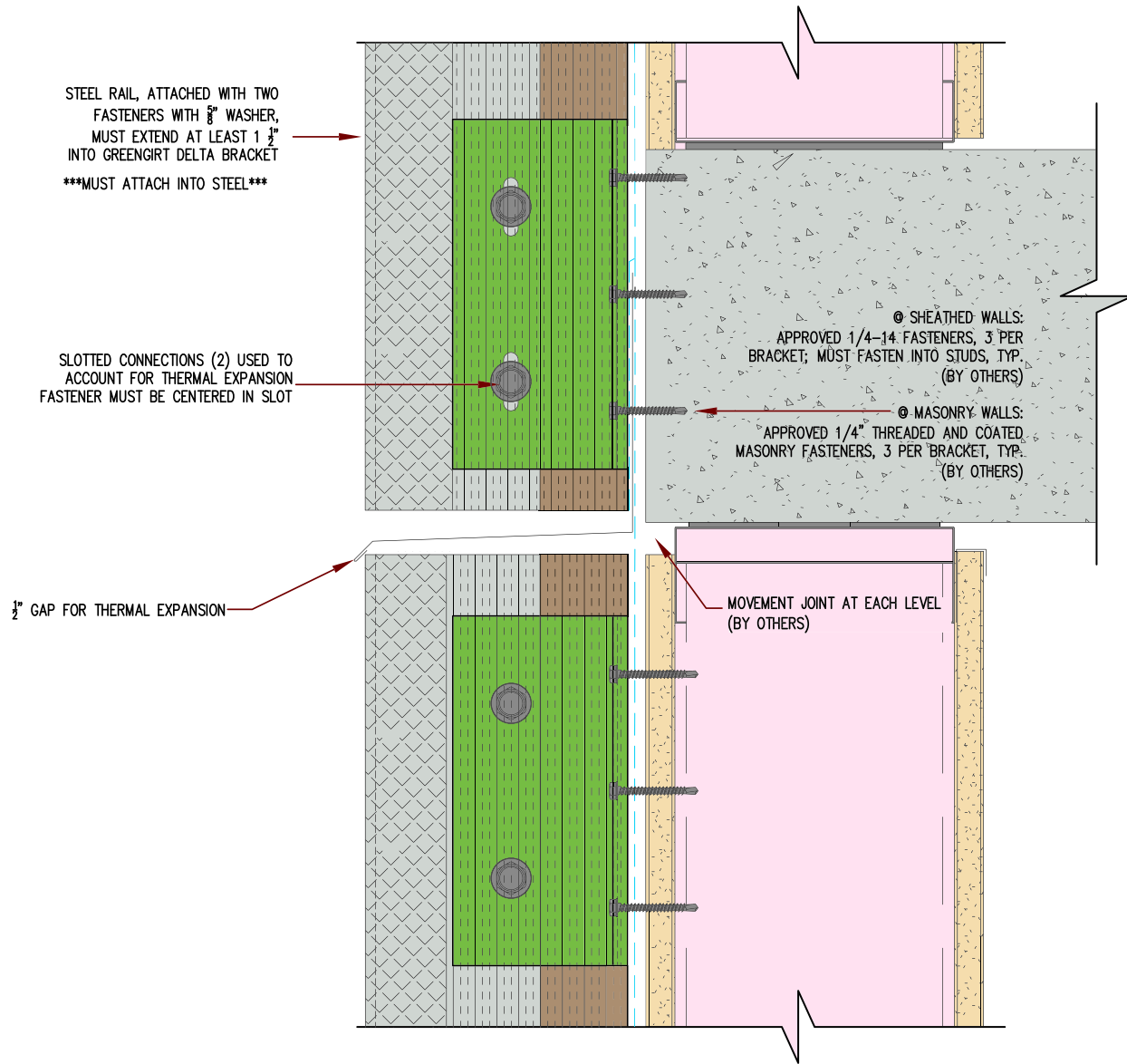

GreenGirt Delta™
 COMPOSITE METAL HYBRID ADJUSTABLE SYSTEM

GreenGirt.com

(269) 355-1818

SUBSTRATE: **SHEATHING W/ METAL STUD**

INSULATION: MINERAL WOOL

CLADDING:

DATE

GREENGIRT DELTA BRACKET SIZE: 300 / 3"

ORIENTATION: VERTICAL Z-BRACKET

DELTA SLIDER (FLOOR JOINT)

NOT TO SCALE



Advanced Architectural Products
959 Industrial Drive, Allegan, MI 49010
(269) 355-1818
GreenGirt.com

© 2026 Advanced Architectural Products. All rights reserved. No part of this publication may be reproduced, distributed, or transmitted in any form or by any means including photocopying, recording, or other electronic or mechanical methods, without the prior written permission of Advanced architectural Products, except in the case of brief quotations embodied in critical reviews and certain other noncommercial uses permitted by copyright law. For permission requests, contact Advanced Architectural Products.

GreenGirt.com/patents/
General revision March 2026